

Series	Description	Size									Mounting		Page	
		1/4	3/8	1/2	3/4	1	06	10	16	Subplate	Screw-in			
	Parker Standard DIN / ISO													
<b>Throttle valves, manual adjustment</b>														
MVI		•	•	•	•							•		5-2
NS		•	•	•	•	•						•		5-4
FS	With free return flow	•	•	•	•	•						•		5-6
<b>Flow control valves, manual adjustment</b>														
PC*MS		•	•	•	•	•						•		5-8
GFG2							•					•		5-10
2F1C									•		•	•		5-14
<b>Flow control valves, proportional adjustment</b>														
DUR*L							•					•		5-20

More flow valves are presented in the following chapters:

- Chapter 7: Sandwich Valves
- Chapter 8: Slip-In Cartridge Valves
- Chapter 9: SAE Flange Valves
- Chapter 10: Valves for Pipe Mounting

**Characteristics / Ordering Code**

Manatrol needle valve with steel body as screw-in valve for block insertion, optionally with a 30° taper fine V-notch or micro-fine rectangular slot. The form of the metering opening influences the accuracy of the flow adjustment, which is pressure and viscosity dependent. The needle is made of stainless steel and fits into a ring gap in the valve cartridge. For details of cutting tools for reaming the block bore, see 'Accessories' at the end of this chapter.

**Characteristic values**

Size	Operating press. [bar]	Flow [l/min] Δp 10 bar	Max. orifice area [cm <sup>2</sup> ]	Kv factor valve	Weight [kg]
400	350	25	0.14	6.3	0.18
600	350	65	0.37	18.5	0.32
800	350	105	0.55	27.5	0.59
1200	350	160	0.90	45.7	0.95
Needle size					
400-2		11	0.52		
400-3		2	0.012		

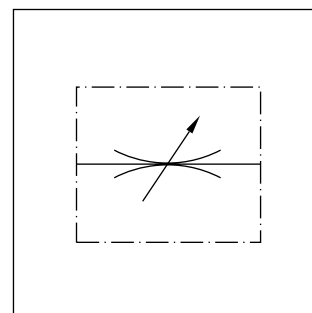
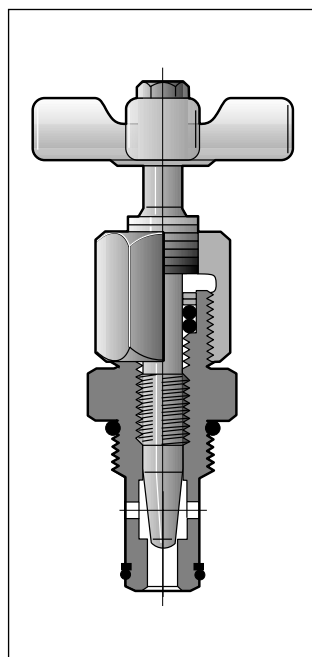

5

Flow rate Q [l/min] =  $K_v \cdot \sqrt{\frac{\Delta p}{\gamma}}$

Kv see table  
 Δp [bar]  
 γ [kg/dm<sup>3</sup>] = specific gravity of fluid  
 (γ for mineral oil = 0.85 – 0.9)

**Δp/Q curves**

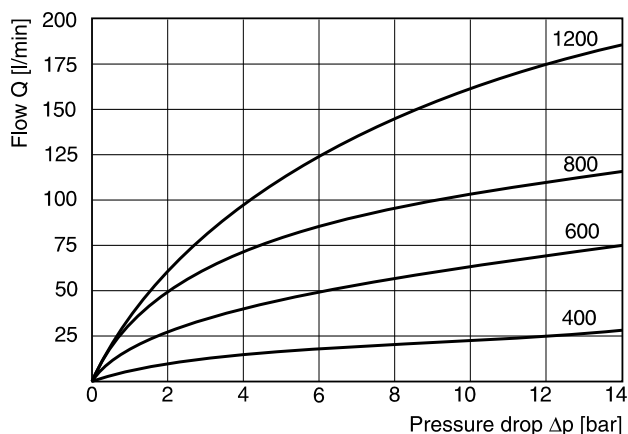

All characteristic curves measured with HLP46 at 50 °C.

**Ordering code**

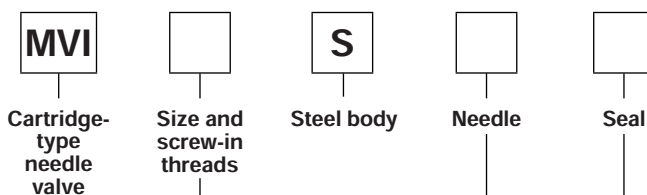

Code	Size	Threads
<b>400</b>	<b>1/4"</b>	<b>3/4 - 16 UNF-2B</b>
<b>600</b>	<b>3/8"</b>	<b>7/8 - 14 UNF-2B</b>
<b>800</b>	<b>1/2"</b>	<b>1 1/16 - 12 UN-2B</b>
<b>1200</b>	<b>3/4"</b>	<b>1 5/16 - 12 UN-2B</b>

Code	Seal
<b>omit</b>	<b>NBR</b>
V	FPM

Code	Needle
<b>omit</b>	<b>Standard 30° taper</b>
2 <sup>1)</sup>	Fine V-notch
3 <sup>1)</sup>	Micro-fine slotted

**Bold letters = Short-term availability**

<sup>1)</sup> only for size 400

**Threaded cartridge valve**

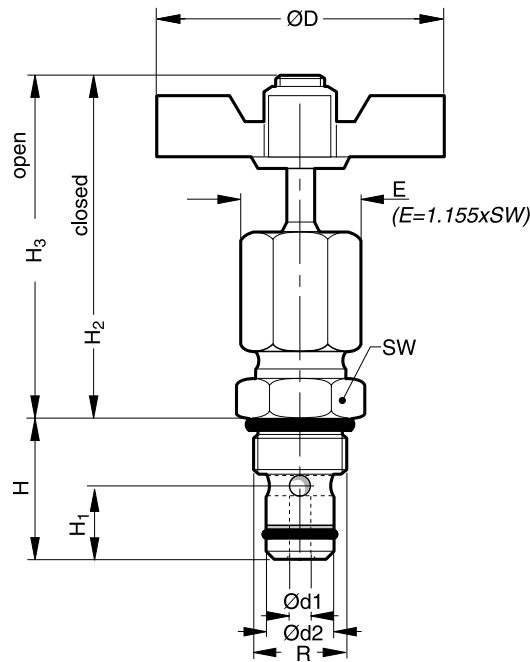

**5**

Size	H	H <sub>3</sub>	H <sub>2</sub>	H <sub>1</sub>	Ød <sub>1</sub>	Ød <sub>2</sub>	R (Threads)	ØD	SW
MVI 400	25.4	65	60	10.9	4.6	14.22	3/4 - 16 UNF-2	51	22.1
MVI 600	30	81	73	13.5	7.9	15.8	7/8 - 14 UNF-2	64	25.4
MVI 800	39.6	91	79	15.2	9.4	20.55	1 1/16 - 12 UN-2	83	31.8
MVI 1200	43.4	102	88	19.1	11.7	26.92	1 5/16 - 12 UN-2	98	38.1

**Mounting cavity**

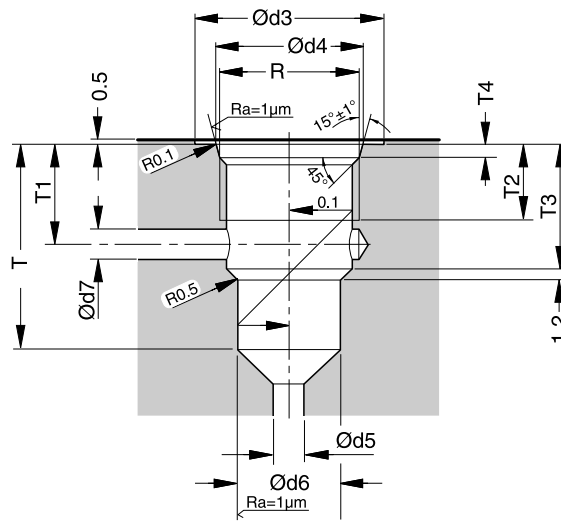

Size	Ød <sub>3</sub>	Ød <sub>4</sub> <sup>+0.12</sup>	Ød <sub>5</sub> (min)	Ød <sub>6</sub> <sup>+0.05</sup>	Ød <sub>7</sub>	T <sub>4</sub> <sup>+0.38</sup>	T <sub>2</sub>	T <sub>3</sub>	T	T <sub>1</sub>
MVI 400	26	20.6	5.3	14.275	5.3	2.54	15	17.8	27	14.2
MVI 600	30	23.93	8.1	15.85	8.1	2.54	17	21.6	32	16.5
MVI 800	37	29.16	10.2	20.6	10.2	3.3	19	30	42	24.1
MVI 1200	44	35.54	12.7	26.975	12.7	3.3	19	31.8	46	24.6

**Cutting tools for MVI valves**

Material	Valve sizes and ordering code		
	400	600	800 and 1200
Cutting alloy	SE 1062	SE 567	on request
Steel	SE 1063	SE 1061	on request

Characteristics / Ordering Code

Manatrol shut-off and metering valves with 2 stage needle cone. Fine adjustment for the first stage can be achieved with 3 rotations of the adjustment knob. The second stage with normal throttle characteristics is achieved with 3 further rotations.

A cylindrical needle with a rectangular slot is provided to reduce the viscosity effect for sizes 400 and 600. The flow is dependent on pressure and viscosity.

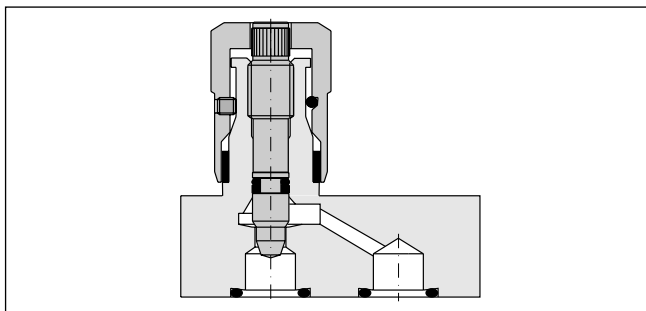
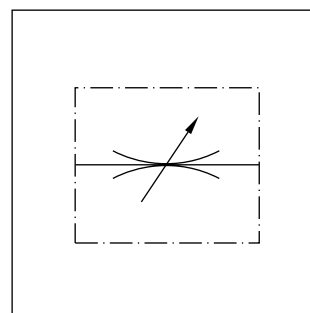

5

Characteristic values

(only for standard 2 stage needle)

Size	Press. [bar]		Flow [l/min] Δp 10 bar	Max. cross-section [cm <sup>2</sup> ]	Kv factor valve open	Weight [kg]
	steel	brass				
400	210	140	25	0.13	6.3	0.4
600	210	140	40	0.22	11.2	0.6
800	210	140	50	0.28	13.9	1.0
1200	210	140	120	0.70	35.4	2.0
1600	210	35	250	1.48	75	4.0

Flow rate Q [l/min] =  $K_v \cdot \sqrt{\frac{\Delta p}{\gamma}}$

Kv from the table  
 Δp [bar] = specific weight of the medium  
 γ [kg/dm<sup>3</sup>] (γ for mineral oil = 0.85 – 0.9)

Ordering code

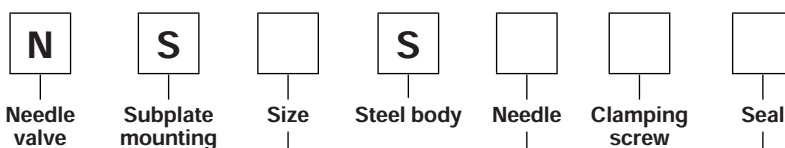

Code	Size
<b>400</b>	<b>400</b>
<b>600</b>	<b>600</b>
<b>800</b>	<b>800</b>
<b>1200</b>	<b>1200</b>
1600	1600

Code	Seal
<b>omit</b>	<b>NBR</b>
V	FPM

Code	Needle
<b>omit</b>	<b>Standard 2 stage needle</b>
4 <sup>1)</sup>	Micro-fine hollow needle with slot

Code	Clamping screw
<b>omit</b>	<b>Hexagon socket</b>
F	With knurled knob

**Bold letters = Short-term availability**

<sup>1)</sup> Only for sizes 400 to 600.

**Δp/Q curves**

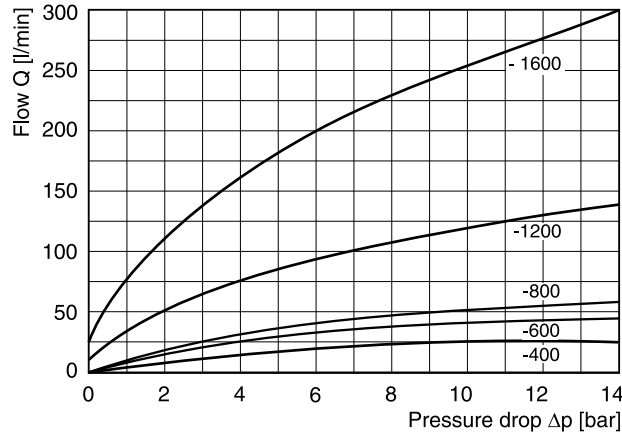

All characteristic curves measured with HLP46 at 50 °C.

**Dimensions**

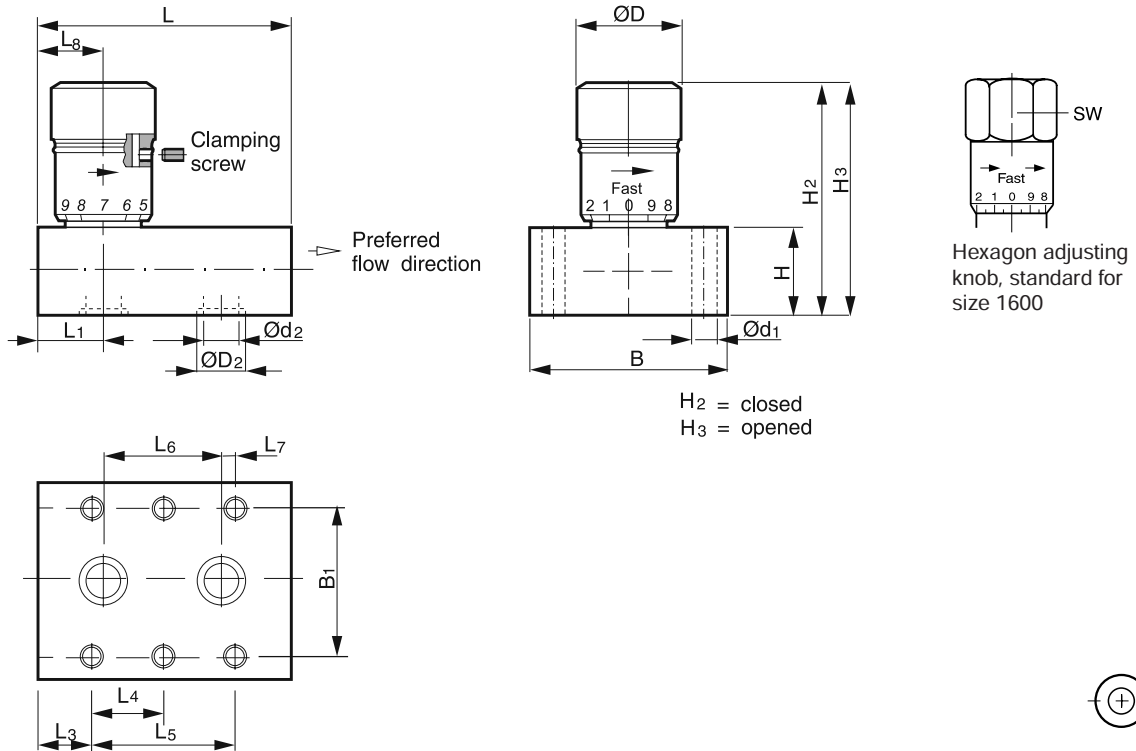

Size	L	L1	L3	L4	L5	L6	L7	L8	B	B1	H	H2	H3	Ød1	Ød2	ØD2	ØD	SW
NS400	47.8	11.2	6.4	-	34.7	25.4	4.5	11.2	44.5	33.3	22.4	49.5	54.6	6.8	7.1	13.3	20.6	-
NS600	50.8	12.7	8.6	-	33.6	25.4	4.1	12.7	50.8	38.1	25.4	61.0	67.3	7.0	8.6	16.0	25.4	-
NS800	75.4	22.6	18.5	-	38.1	30.2	3.8	22.6	57.2	44.4	25.4	70.0	77.2	7.0	11.9	19.1	30.0	-
NS1200	93.7	19.8	8.6	38.1	76.2	54.4	10.6	19.8	69.9	54.1	28.4	79.3	94.5	9.5	16.8	24	34.8	-
NS1600	111.3	26.9	7.9	47.8	92.2	57.2	16.0	26.9	76.2	60.4	44.5	123.2	140.0	9.5	22.4	32	-	47.5

NS UK.indd RH 30.07.2013

**Characteristics / Ordering Code**

Manatrol throttle check valves series FS allow the adjustment of the flow for a defined direction.

A 2 stage needle allows for very exact setting of smaller flow rates with the first 3 rotations of the adjustment knob. After 3 more rotations, the valve is completely open. The valve setting can be locked by a locking screw.

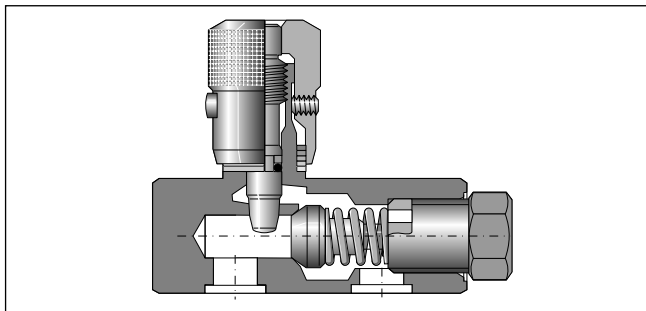
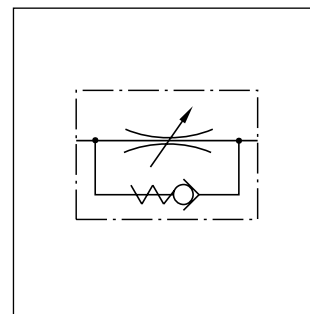

$$\text{Flow rate } Q \text{ [l/min]} = K_v \cdot \sqrt{\frac{\Delta p}{\gamma}}$$

$K_v$  from the table  
 $\Delta p$  [bar]  
 $\gamma$  [kg/dm<sup>3</sup>] = specific gravity of fluid  
 (γ for mineral oil = 0.85 – 0.9)

**Characteristic values**

Size	Pressure [bar]	Max. flow [l/min Δp10 bar]	Opening [cm <sup>2</sup> ]	Check Kv factor	Throttle surface [cm <sup>2</sup> ]	Throttle v. open Kv factor	Weight [kg]
400*	210	25	0.37	18.6	0.13	6.3	0.23
600*	210	40	0.62	30.4	0.22	11.2	0.31
800*	210	50	0.86	43.4	0.28	14	0.67
1200*	210	120	1.18	60	0.70	35.4	1.17
1600*	210	250	2.23	111	1.48	75	2.31

\* MTTF<sub>0</sub> value 150 years

**Ordering code**

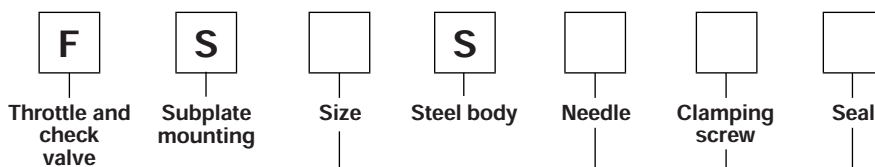

Code	Size
400	400
600	600
800	800
1200	1200
1600	1600

Code	Needle
omit	<b>Standard 2 stage needle</b>
4 <sup>1)</sup>	Micro-fine hollow needle with slot

Code	Seal
omit	<b>NBR</b>
V	FPM

Code	Clamping screw
omit	<b>Hexagon socket</b>
F	With knurled knob

**Bold letters = Short-term availability**

<sup>1)</sup> Only for sizes 400 to 600.

**Δp/Q performance curves**

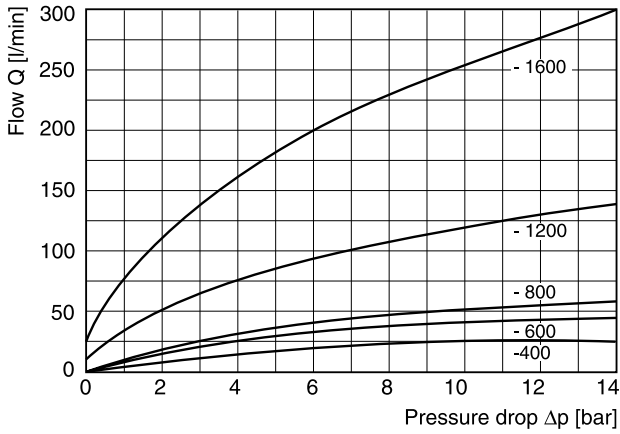

**Δp/Q performance curves free flow**

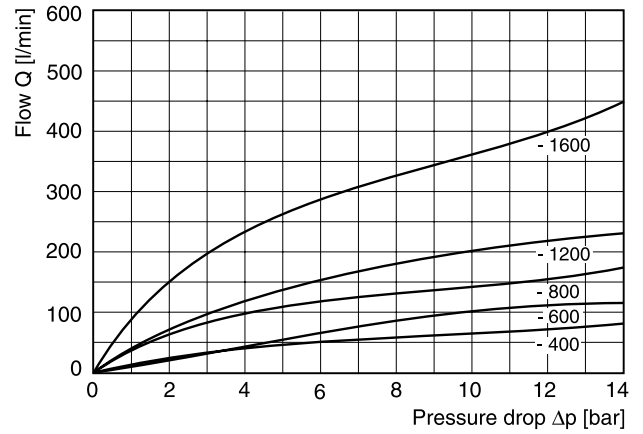

All characteristic curves measured with HLP46 at 50 °C.

**5**

**Dimensions**

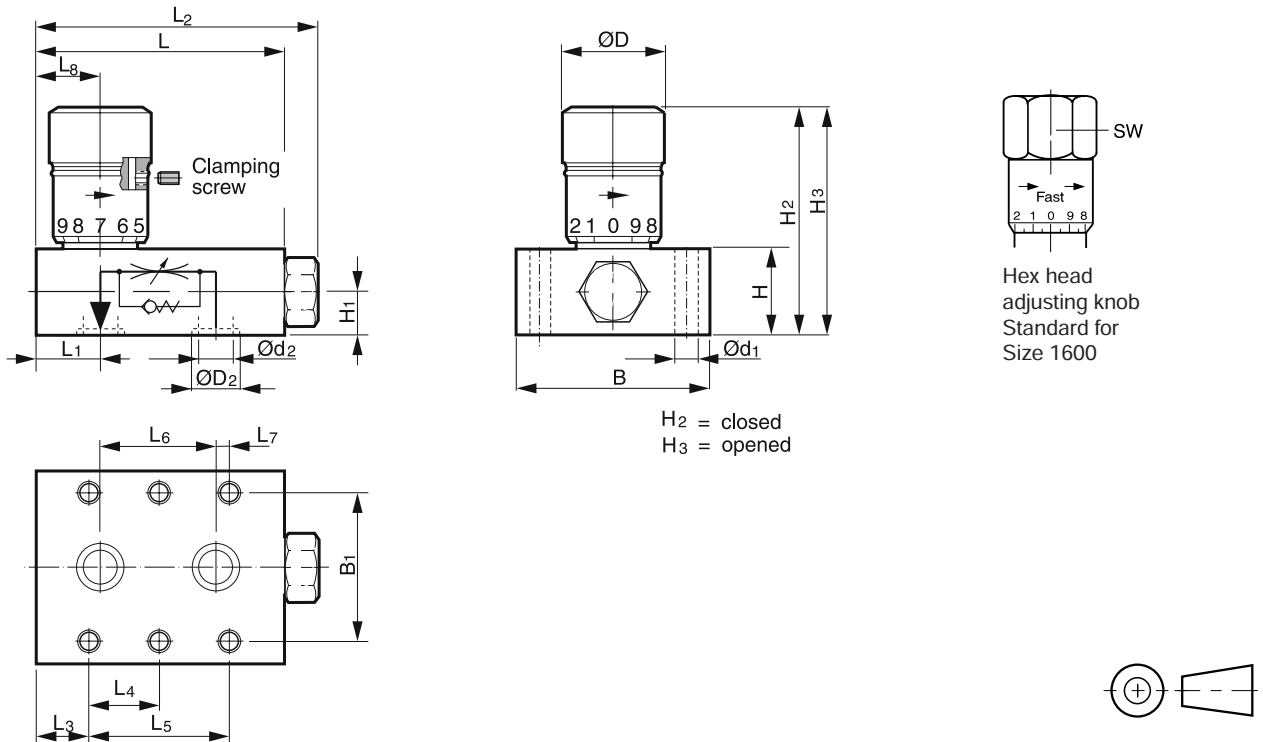

Size	L	L1	L2	L3	L4	L5	L6	L7	L8	B	B1	H	H1	H2	H3	Ød1	Ød2	ØD2	ØD	SW
FS400	63.5	19.1	71.4	14.2	-	35.1	25.4	4.8	21.3	44.5	33.3	22.1	10.9	51.1	56.1	6.8	7.1	13.3	20.6	
FS600	69.9	22.4	78.0	18.3	-	33.3	25.4	3.8	25.4	50.8	38.1	25.4	12.7	61.0	67.3	7.0	10.4	16	25.4	
FS800	81.0	25.4	89.2	21.3	-	38.1	30.2	3.8	30.7	57.2	44.5	31.8	15.7	76.2	83.6	7.0	11.9	19.1	30.0	
FS1200	103.9	25.1	114.6	14.0	38.1	76.2	54.102	10.9	38.6	69.9	54.1	44.5	22.1	95.5	110.5	9.0	16.8	24	34.8	
FS1600	127.0	35.1	137.7	15.7	47.8	95.5	56.896	19.3	45.2	76.2	60.5	50.8	25.4	129.5	146.3	9.0	22.4	32		47.5

**Characteristics / Ordering Code**

Manatrol 2 way flow control valves for pressure compensated regulation of the flow. As a consequence of pressure changes, the set value can vary by  $\pm 5\%$  within the tolerance range. Changes in viscosity and in temperature have the same effect and are to be observed.

The series PCCMS is additionally equipped with a built-in check valve for the return flow.

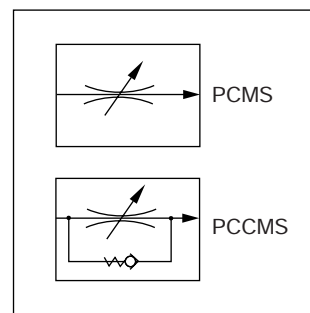

**Characteristic values**

Size	Max. press. [bar]	Flow control		Check valve		Weight [kg]
		Q <sup>1)</sup> [l/min]	$\Delta p$ [bar]	Q <sub>max</sub> [l/min]	$\Delta p$ [bar]	
400	210	1 - 10	7	20	3	0.77
600	210	2 - 25	7	30	3	1.23
800	210	6 - 60	11	75	8	2.50
1200	210	10 - 100	11	130	8	3.18
1600	210	19 - 190	11	250	10	7.41

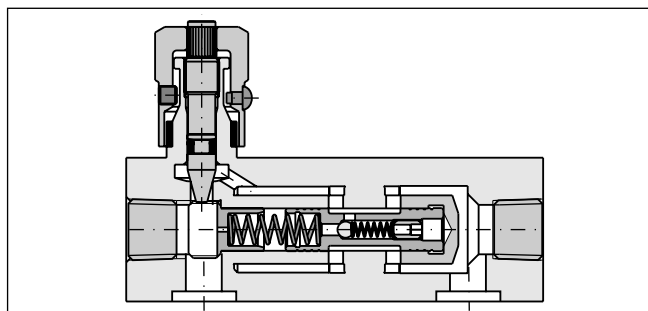

**Ordering code**

<b>PC</b>		<b>M</b>	<b>S</b>		<b>S</b>				
Pressure compens. flow control valvel	Check valve	Manual adjustment	Subplate mounting	Size	Steel body	Clamping screw	Seal	Design series (not required for ordering)	

Code	Check valve								
<b>omit</b>	<b>Without check valve</b>							Code	Seal
C	With check valve							<b>omit</b>	<b>NBR</b>
								V	FPM

Code	Nominal size								
400	400							Code	Clamping screw
<b>600</b>	<b>600</b>							<b>omit</b>	<b>Hexagon socket</b>
<b>800</b>	<b>800</b>							F	With knurled knob
1200	1200								
1600	1600								

**Bold letters = Short-term availability**

<sup>1)</sup> Min. and max. flow rate.



Controlled flow vs. pressure drop

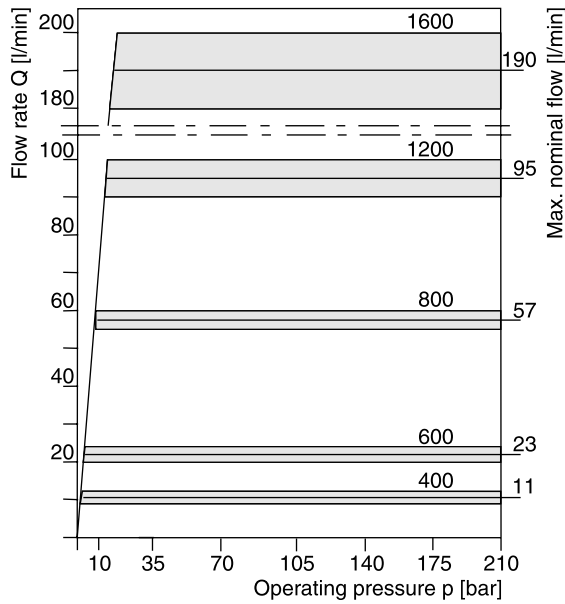

All characteristic curves measured with HLP46 at 50 °C.

Reverse flow vs. pressure drop at minimum and maximum settings

Sizes 400, 600 and 1200

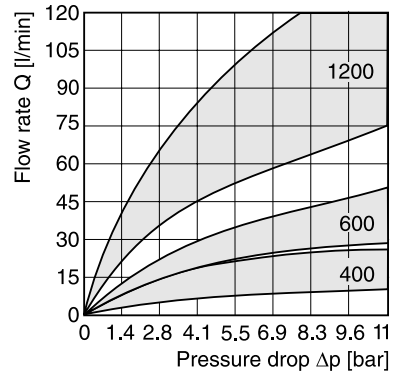

Sizes 800 and 1600

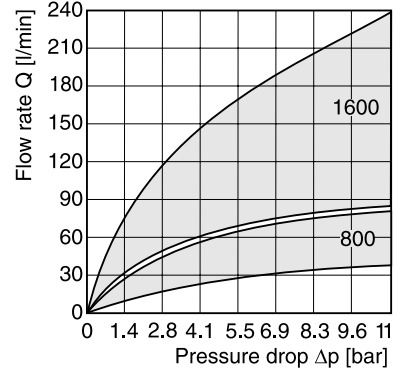

Dimensions

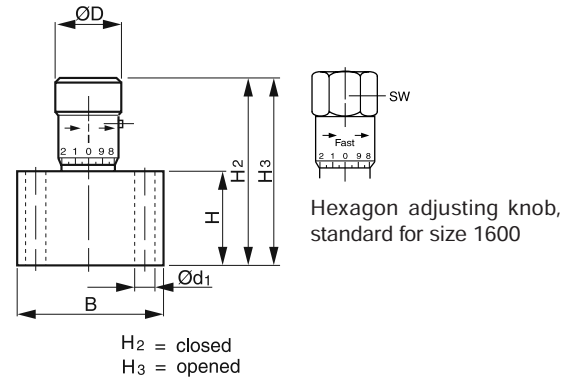
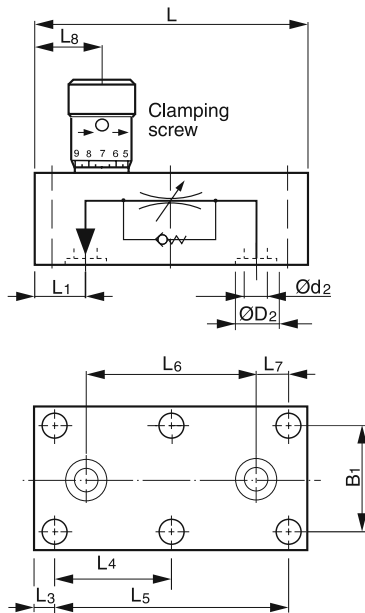

Size	L	L1	L3	L4	L5	L6	L7	L8	B	B1	H	H2	H3	Ød1	Ød2	ØD2	ØD	SW
400	85.9	15.7	6.4	-	72.8	54.2	9.3	21.3	44.5	33.3	28.4	57.7	62.7	6.8	7.1	13.3	20.6	
600	101.6	16.8	6.4	-	88.9	68.0	10.5	25.4	50.8	38.1	31.8	67.8	73.4	7.0	8.6	16.0	25.4	
800	117.3	19.1	6.4	-	104.9	79.5	12.7	44.5	57.2	44.4	44.5	95.0	102.6	7.0	11.9	19.1	30.0	
1200	142.7	25.4	9.7	61.7	123.7	91.9	16.1	40.4	69.9	54.1	57.2	115.8	128.5	9.5	16.8	24.0	34.8	
1600	171.5	31.8	12.7	73.2	146.1	107.9	19.1	49.3	76.2	60.4	69.9	158.2	175.3	9.5	22.4	32.0	47.5	

**Characteristics**

2 way flow control valves are used to provide pressure compensated flow. The valve design compensates temperature variations to a certain extent.

The GFG is optionally equipped with a built-in check valve for the return flow.

**Design**

The 2 way flow control valves are used with a triangular flow restrictor and a subsequent pressure compensator. The setting of the flow rate can be locked by a key lock in the adjusting knob against unauthorized adjustment (option C).

**Function**

The fluid enters through port A through the flow restrictor. Downstream of the flow restrictor the pressure compensator is located. The control edges are provided by four radial bores in the poppet, which are fully open to port B in the neutral position.

Optionally the flow from A to B can be blocked by external pilot pressure applied to port P (option X). This can be used to avoid unintended initial movements of actuators.

The flow adjustment is done via the hand knob with an adjusting angle knob of 270°.

**Features**

- Flow rate independent of pressure and temperature
- Available for 7 different flow rates
- Good fine adjustment
- External port (P) to block flow from A to B
- Optional reverse flow check valve
- Turn knob with key lock (option C)

**Note**

Rectifier plate and subplates see 'Accessories' at the end of this chapter.

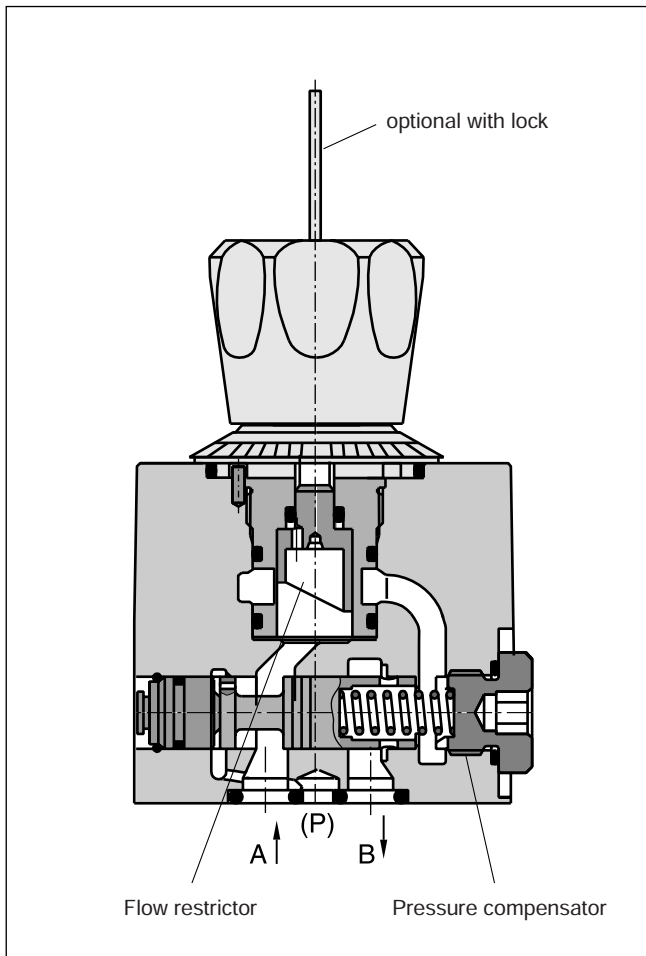
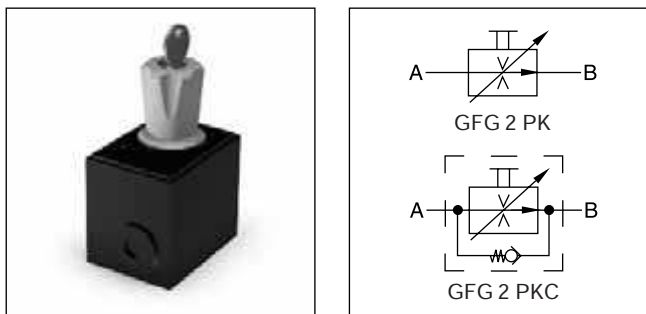

5

Ordering code

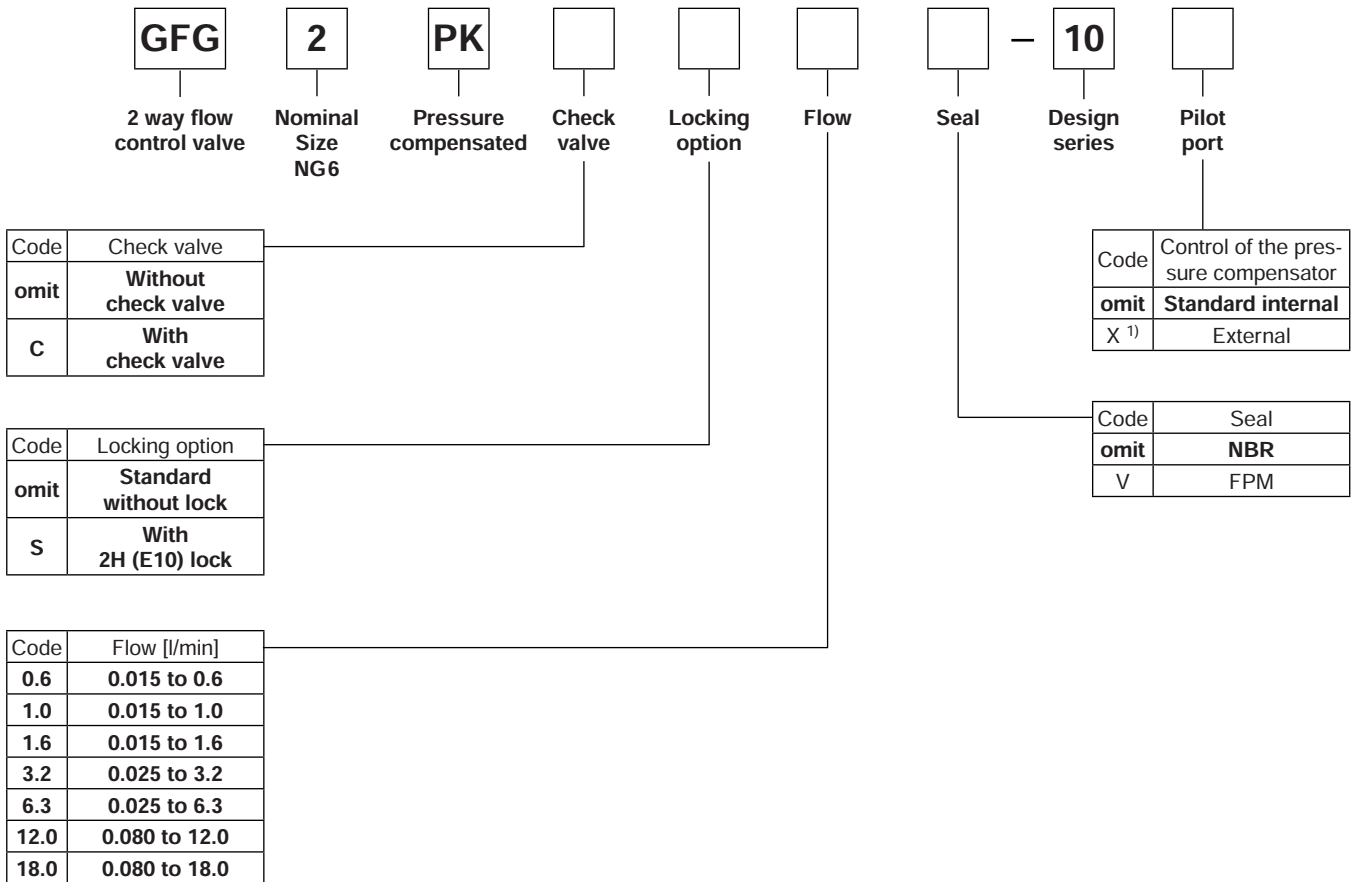

5

**Bold letters = Short-term availability**

<sup>1)</sup> Only in combination with integrated check valve.

Technical data

General	
Design	Orifice, infinitely variable, pressure-compensated
Actuator	Manual flow rate adjustment
Mounting type	ISO 6263 code: ISO 6263-AB-03-4-B
Mounting position	unrestricted
MTTF <sub>D</sub> value	[years] 150
Weight	[kg] 1.1 (without subplate)
Fluid	Hydraulic oil according to DIN 51524 ... 51525
Fluid temperature	[°C] max. 70
Ambient temperature	[°C] -25...+50
Viscosity range	[cSt] / [mm <sup>2</sup> /s] 2.8...400
Filtering	[µm] ISO 4406 (1999); 18/16/13
Min. pressure difference	[bar] 5 (GFG*1.6/3.2), 8.5 (GFG*6.3/12/18)
Operating pressure	[bar] A; B = 315 , P = 5 (GFG*, GFG*C), A, B, P = 160 (GFG*X)
Effect of pressure on Q <sub>max</sub> at p = 160 bar	[%] ± 2 (GFG*1.6/3.2/6.3/12), ± 2.5 (GFG*18)
Flow direction	
A → B	Flow control function
B → A	Throttle function or free flow through check valve

**Performance curves**

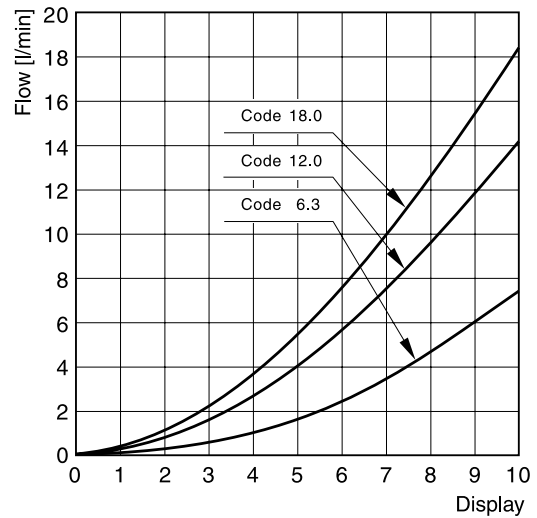
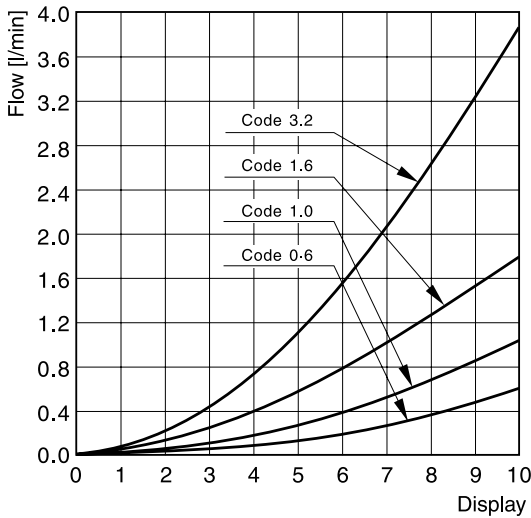

All characteristic curves measured with HLP46 at 50 °C.

Changes in pressure cause a change of pre-set flow rate. Flow rate deviations a  $Q_{max} \pm 2\%$

**Dimensions**

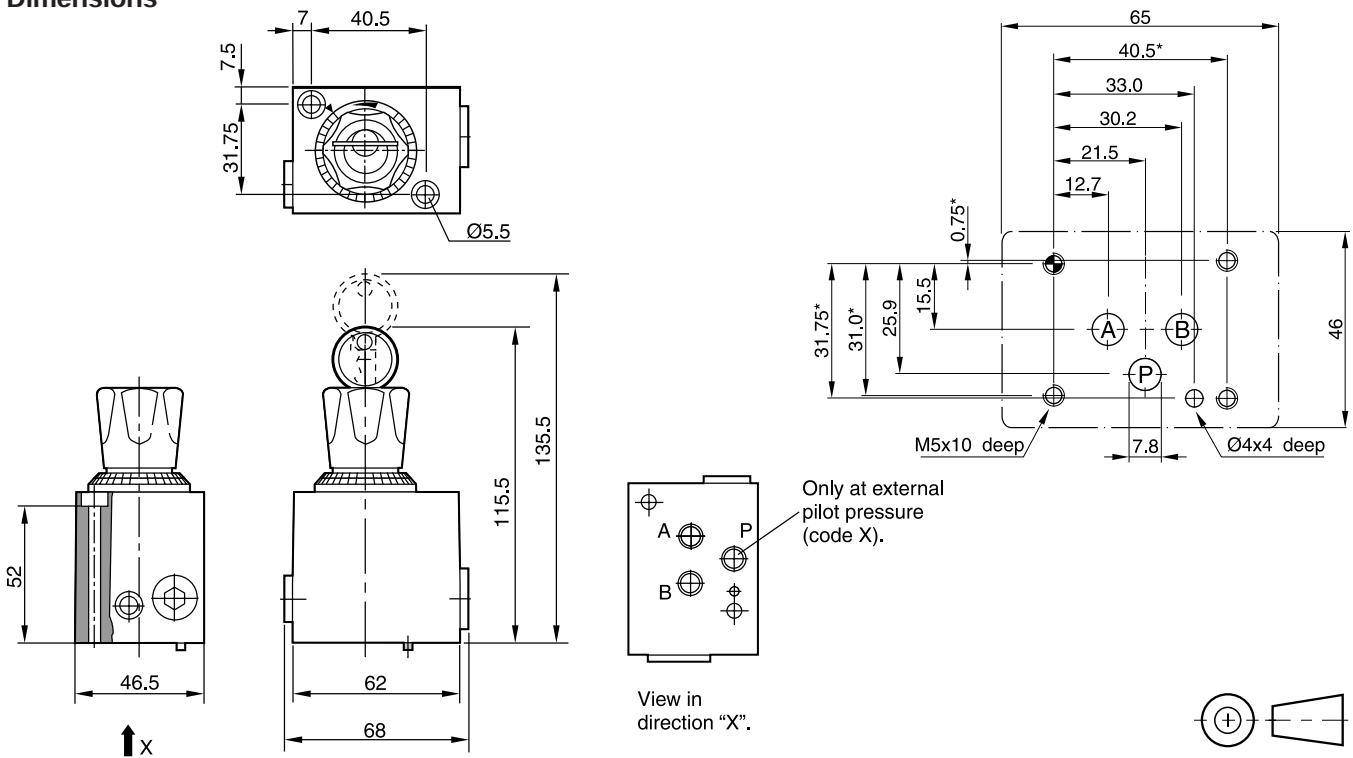

**Bolt kits** (Cylinder head ISO 4762-12.9 not included)

Nominal size Valve	Valve model	Quantity	Tightening torque [Nm]	Valve without rectifier plate Dimensions	Order No.	Valve with rectifier plate Dimensions	Order No.
NG6	GFG2	2	7.6 Nm	2xM5x60	BK380	2xM5x100	BK466

**O-rings for sealing the connecting surface**

Nominal size Valve	Valve model	Ports	Dimensions $\text{Ø}$ -inner x cord thickness	Quantity	Seal kits	
					NBR	FPM
NG6	GFG2	A and B	9x1.5	3	SK-GFG2	SK-GFG2 FPM

**Sandwich rectifier plate**

If a 2 way flow control valve is used in combination with a rectifier plate the valve can be used for meter-in and meter-out flow control of an actuator.

**Design**

The intermediate rectifier plate is designed with 4 identical, symmetrically arranged check valves. Thus the differential pressure is the same in both flow directions.

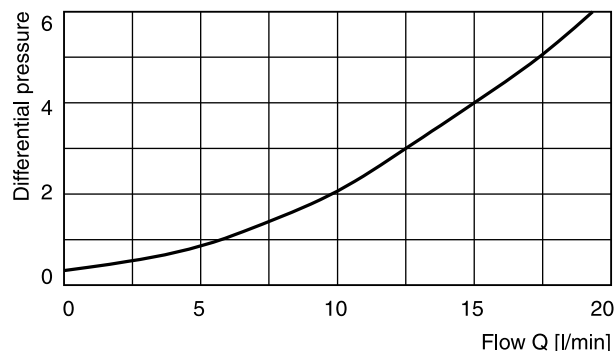
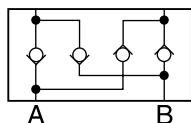

Measured with HLP46 at 50 °C.

**Dimensions**

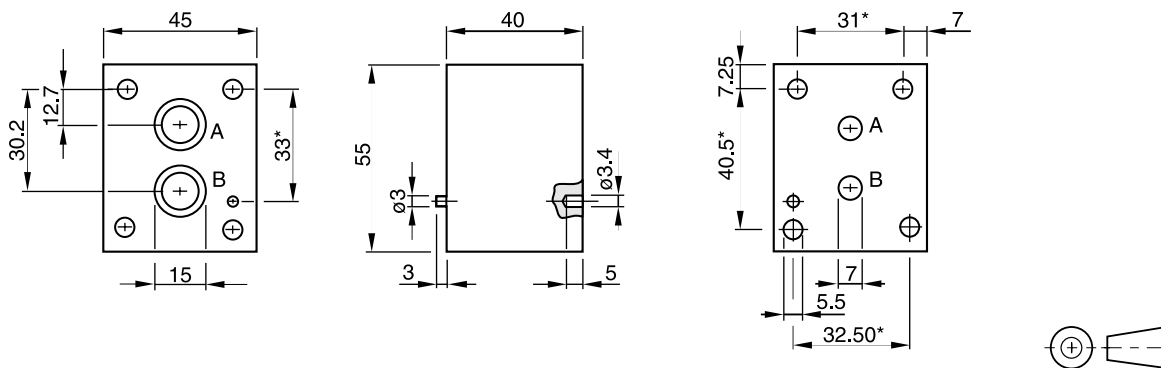

Dimension tolerances  
 \* :  $\pm 0.1$  mm  
 others :  $\pm 0.2$  mm  
 holes and silhouette of valve body : untoleranced dimension

**Ordering code:** HR OA 06 C

**O-ring for sealing the connecting surface**  
 (not included)

Connections	Dimensions	required units
A, B	12 x 1.5	2

**Subplates <sup>1)</sup>**

Ordering code	
SPD 22 B 910	P, A, B and T = G1/4
SPD 23 B 910	P, A, B and T = G1/8

<sup>1)</sup> Details see chapter 12, series SPD.

**Characteristics / Ordering Code**

2 way flow control valves series 2F1C provide pressure and viscosity compensated flow from port A to port B. The counter direction is blocked (standard) or can be open via an integral reverse flow check valve (optional).

**Function**

The compensator spool is located in front of the metering spool. The metering spool is closed in the neutral position to avoid undesired initial actuator motion. The oil flow to open the metering spool has to pass a needle valve (not shown in the sectional drawing). The needle valve can be adjusted from the front panel to set the response time of the 2F1C.

The metering spool is adjusted by the main control knob. The key lock has three positions:

- Lock: Adjustment is locked.
- Adjust: Full adjustment is permitted.
- Trim: Fine adjustment of  $\pm 5\%$  is possible.

**Features**

- 2 way flow control valve
- Subplate mounting according to ISO 6263
- Excellent fine adjustment
- Adjustable response time
- Closed in neutral position
- Optional reverse flow check valve
- 2 sizes, NG10 (3/8"), NG16 (3/4")

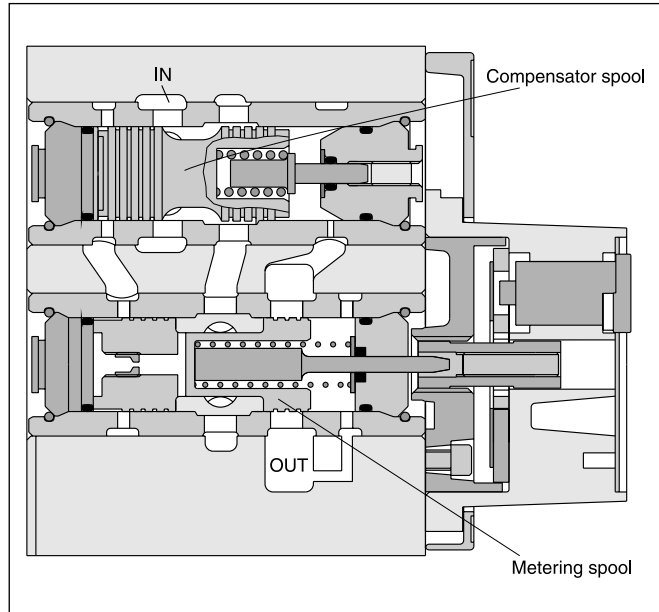
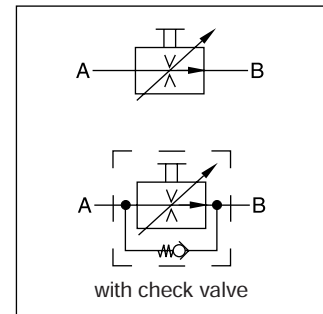

5

**Ordering code**

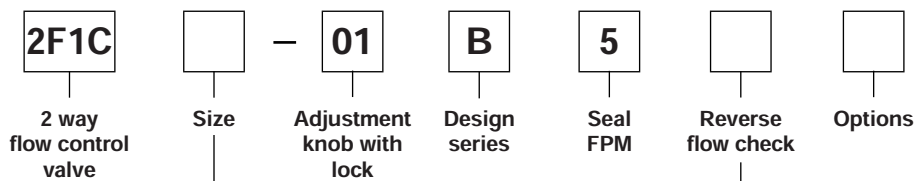

Code	Size
02	NG10 (3/8")
03	NG16 (3/4")

Code	Check valve
0	without check
C	with check

**Technical Data**

General			
Design	Orifice, infinitely variable, pressure-compensated		
Actuator	Manual flow rate adjustment		
Mounting type	ISO 6263		
MTTF <sub>D</sub> value	[years]	150	
Mounting position	unrestricted		
Weight	[kg]	6.0 (2F1C02), 9.0 (2F1C03)	
Fluid	Hydraulic oil according to DIN 51524 ... 51525		
Fluid temperature	[°C]	max. 70	
Ambient temperature	[°C]	-25...+50	
Viscosity range	[cSt] / [mm <sup>2</sup> /s]	2.8...400	
Filtering	ISO 4406 (1999); 18/16/13		
Min. pressure difference	[bar]	see diagram	
Max. operating pressure		2F1C02	2F1C03
Port A	[bar]	14...280	14...350
Port B	[bar]	0...270	0...340
Flow direction A → B B → A	Flow control function blocked or free flow through check valve		

**5**

**Performance curves**

**Flow / knob adjustment characteristics at 210 bar**

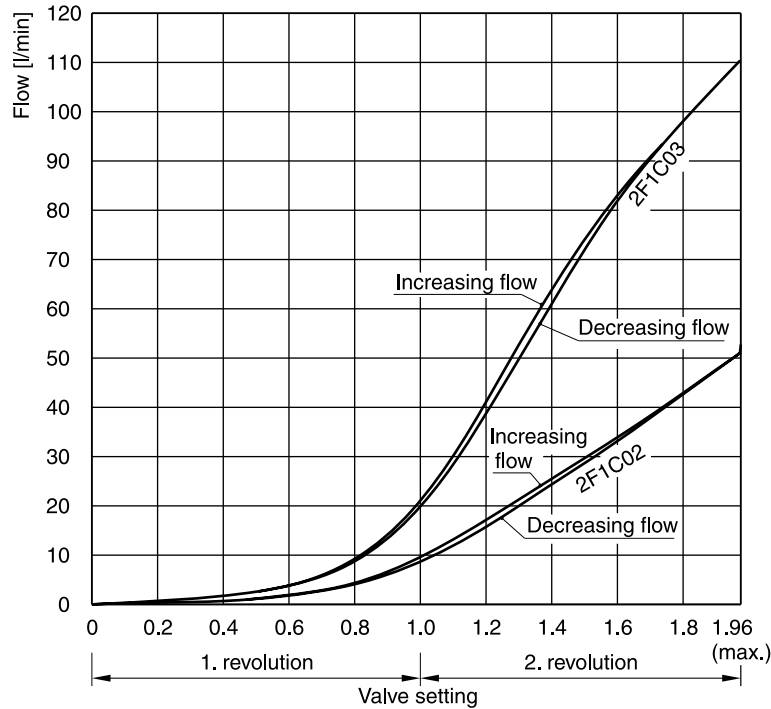

**Flow / pressure drop curves**

Constant inlet pressure – variable outlet pressure

**2F1C02**

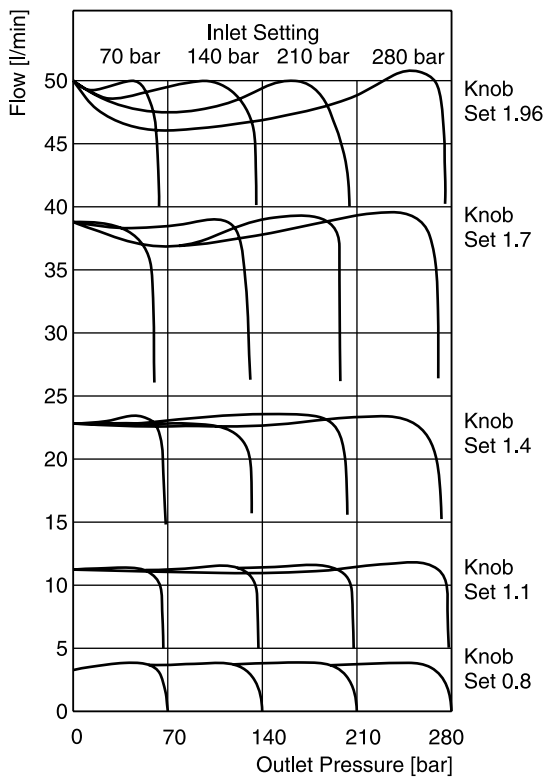

**2F1C03**

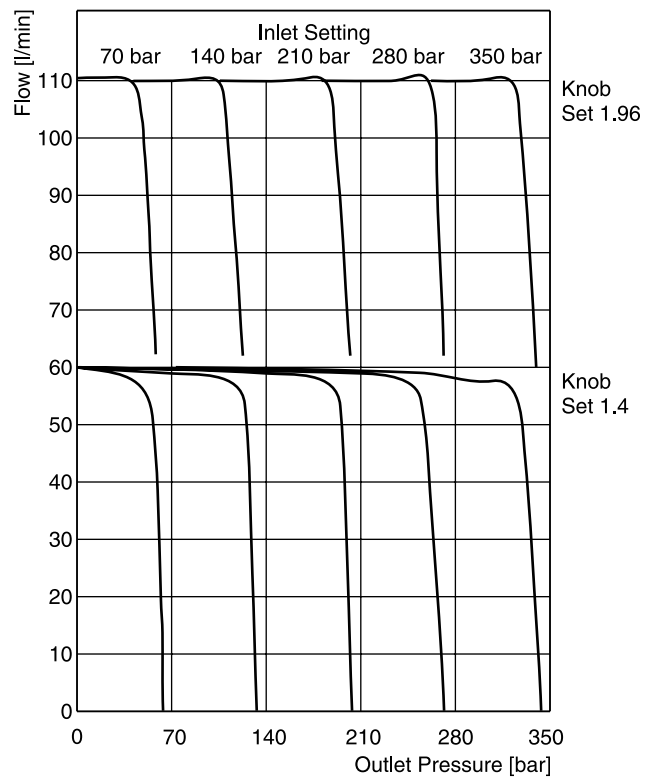

All characteristic curves measured with HLP46 at 50 °C.

2F1C UK.indd RH 30.07.2013

5



**$\Delta p/Q$  performance curves**

for reverse flow direction

2F1C02 at 280 bar

2F1C03 at 350 bar

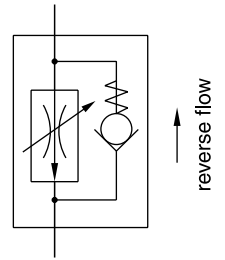
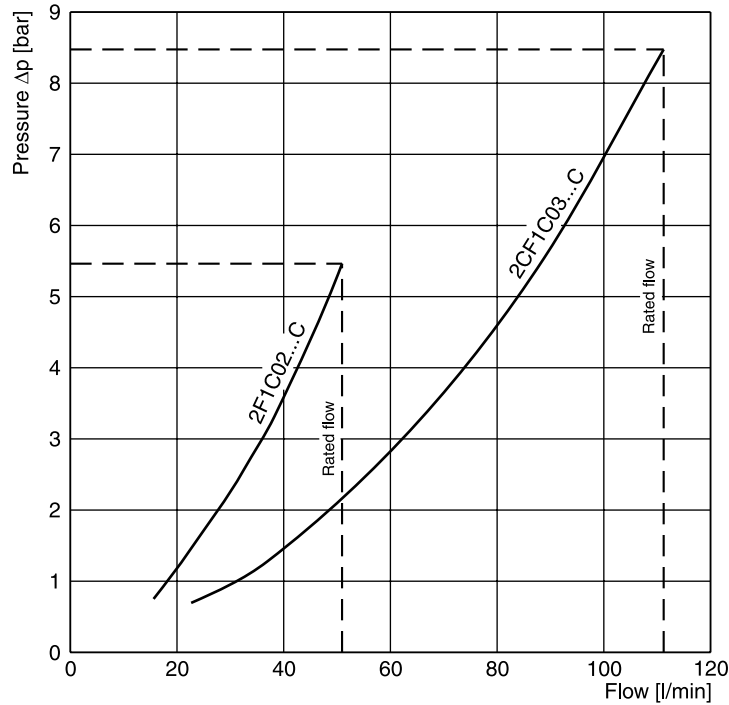

**5**

**Minimum pressure difference curves**

**2F1C02**

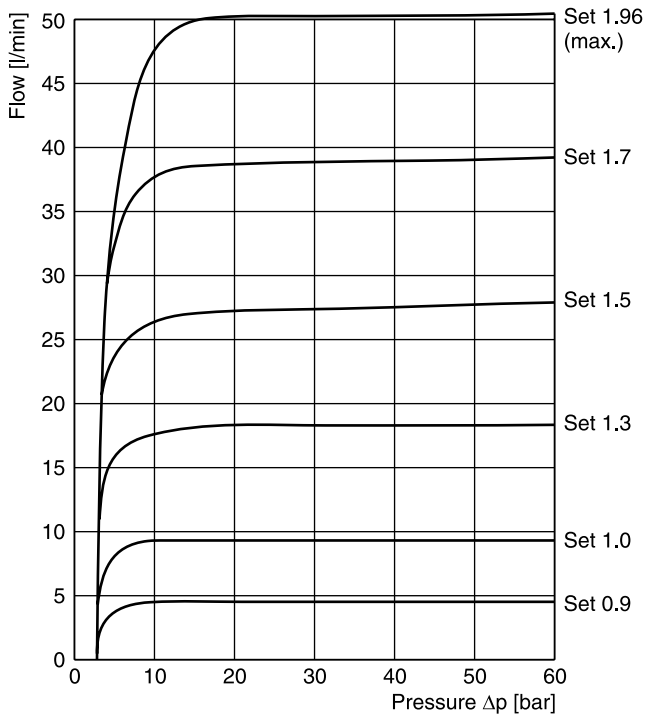

**2F1C03**

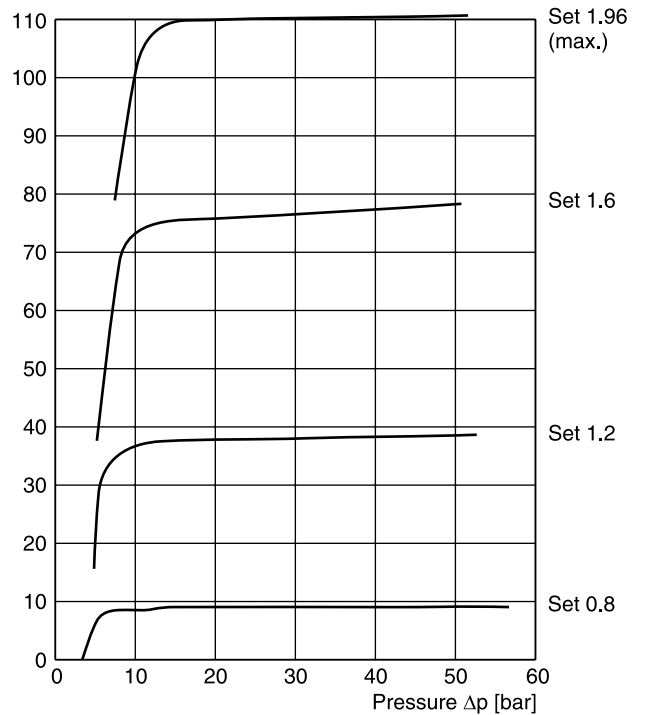

All characteristic curves measured with HLP46 at 50 °C.

2F1C UK.indd RH 30.07.2013

**Leakage / pressure curves**

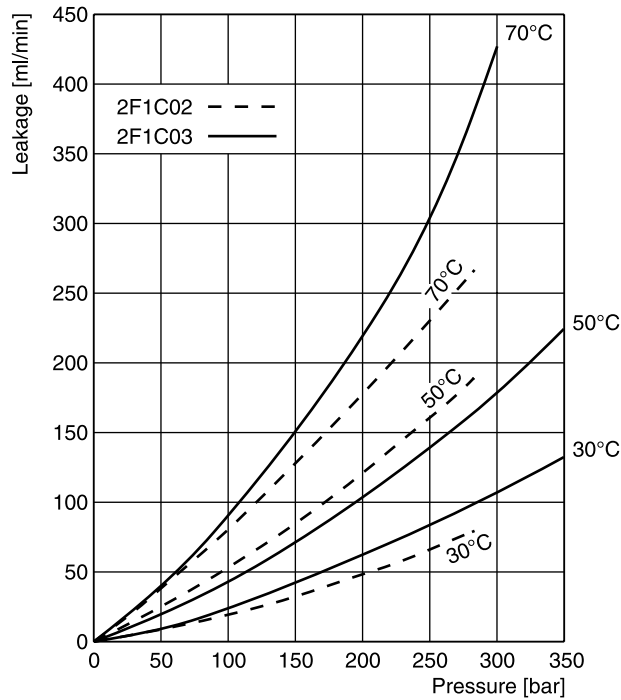

**Flow / temperature curves at 210 bar**

**2F1C02**

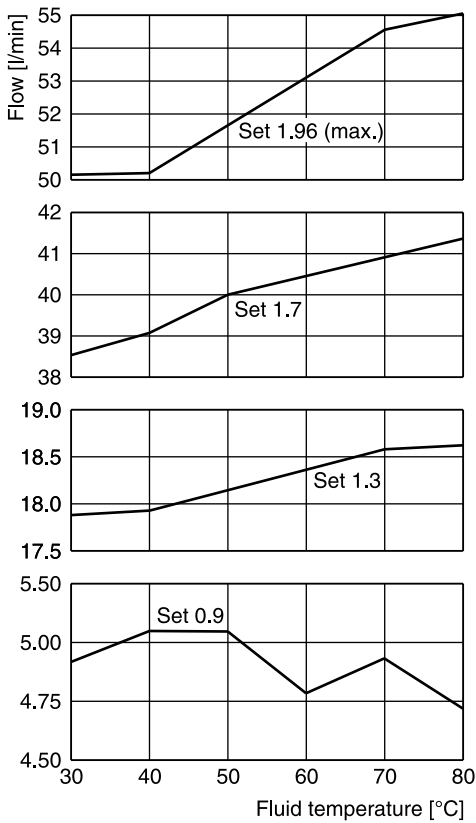

**2F1C03**

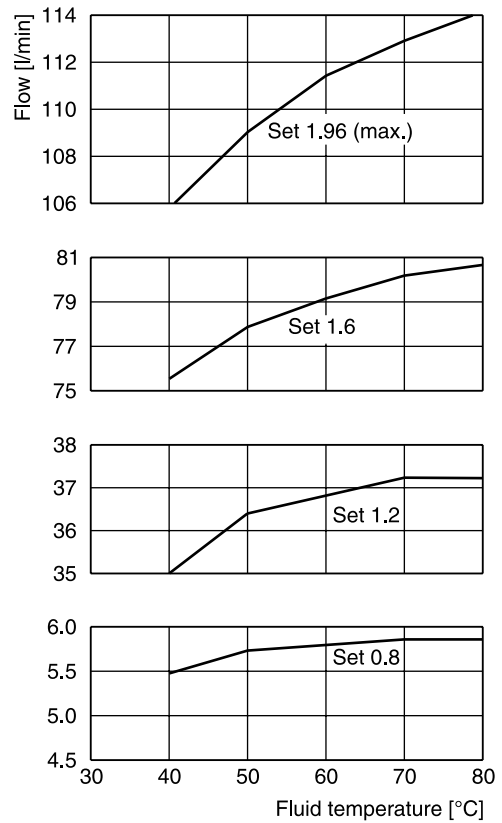

All characteristic curves measured with HLP46 at 50 °C.

2F1C UK.indd RH 30.07.2013

5

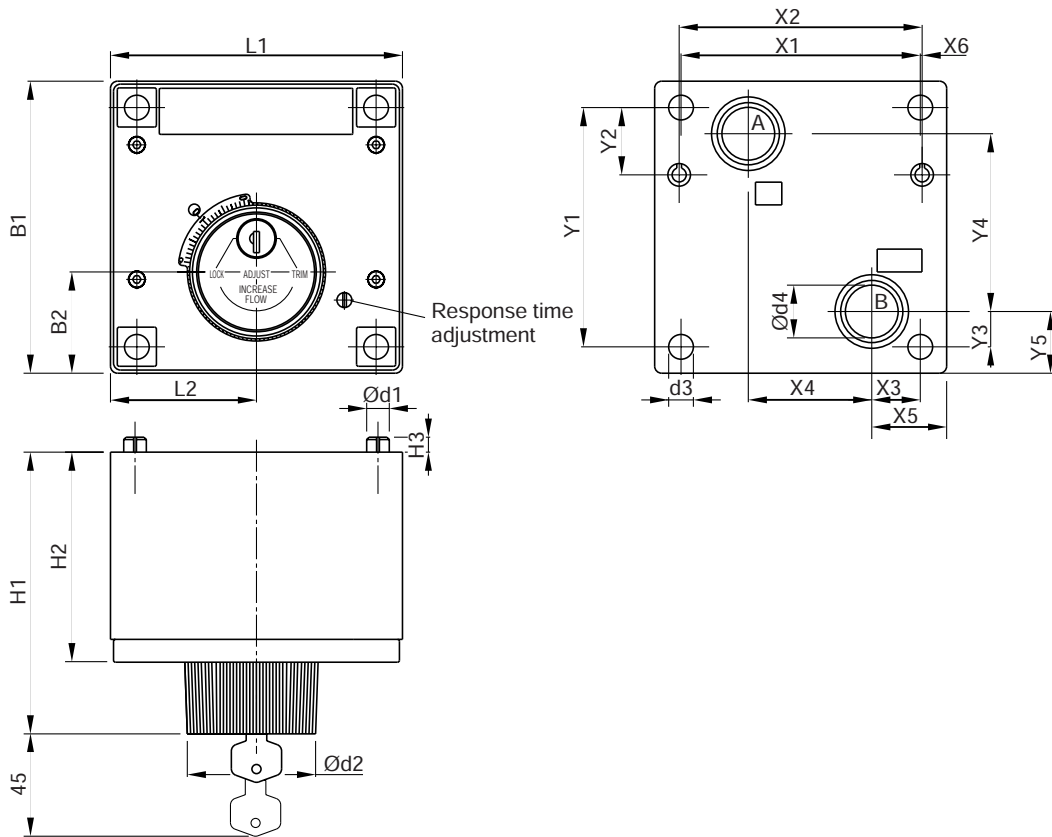



**5**

Size	ISO-code	x1	x2	x3	x4	x5	x6	y1	y2	y3	y4	y5
02	6263-AM-07-2-A	76.2	79.4	9.5	44.5	19	-	82.5	23.8	30.2	41.3	39.7
03	6263-AK-06-2-A	101.6	103.2	20.6	52.4	31.8	0.8	101.6	28.6	15.1	75.4	26.2

Size	ISO-code	B1	B2	H1	H2	H3	L1	L2	d1	d2	d3	d4
02	6263-AM-07-2-A	101.6	38.1	119.6	87.4	6.4	95.2	47.6	6.4	57.2	8.7	14.2
03	6263-AK-06-2-A	124	42.9	121.4	89.2	6.4	124	62	9.5	57.2	10.5	22.4

NG	ISO-code	Bolt kit -  ISO 4762-12.9		 Kit	Surface finish
02	6263-AM-07-2-A	BK538 4x M8x95	31.8 Nm ±15 %	on request	$\sqrt{R_{max} 6.3}$ 
03	6263-AK-06-2-A	BK539 4x M10x95	63 Nm ±15 %	on request	$\sqrt{R_{max} 6.3}$ 

**Characteristics / Ordering Code**

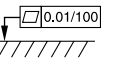
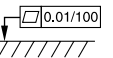
Proportional flow control valves of the series DUR\*L06 are used to generate pressure-compensated flow from A to B. The valve is equipped with a built-in check valve for the return flow.

For meter-in and meter-out control of an actuator a rectifier plate can be used.

**Function**

When solenoid current is applied, the metering spool opens against the reset spring and the flow is regulated by the pressure compensating spool to port B.

With the aid of the pressure compensating spool, the pressure drop is held constant on the metering window. Thus pressure load changes are compensated, and the oil flow remains constant.

In combination with the digital electronic module PCD00A-400 the valve parameters can be saved changed and duplicated.

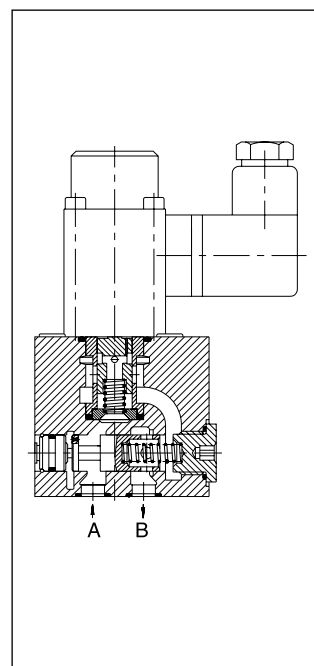
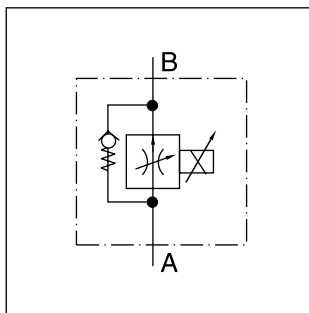

5

**Technical features**

- Low hysteresis
- High reproducibility
- Load-independent oil flow
- Bypass check valve
- Mounting pattern to ISO 6263
- 5 flow rates

**Note**

Rectifier plate and subplates see 'Accessories' at the end of this chapter.

**Ordering code**

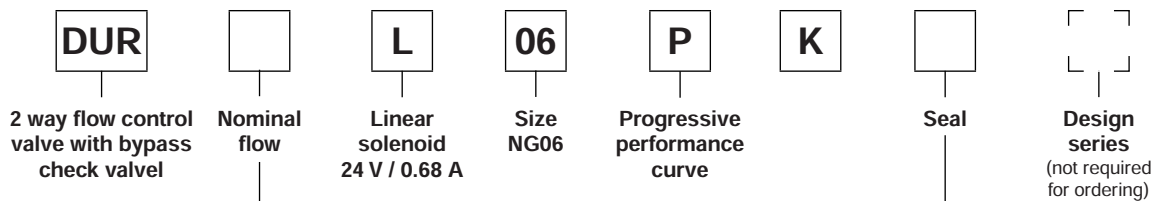

Code	Flow [l/min]
1,6	1.6
3,2	3.2
6,3	6.3
12	12.0
18	18.0

Code	Seal
A	NBR
1	FPM

**Technical data**

General	
Design	Electrically adjustable orifice valve with load sensing
Mounting type	Subplate NG06, Interface DIN 24340, ISO, CETOP
Mounting position	Unrestricted, horizontal mounting preferred
Ambient temperature	[°C] -20 °C...+50
MTTF <sub>D</sub> value	[years] 150
Weight	[kg] 1.6
Type of voltage	[V] 24
Solenoid nominal current	[mA] 680
Duty cycle	100 % ED
Solenoid connection	Connector as per EN 175301-803
Protection class	IP 65 in accordance with EH60529 (with correctly mounted plug-in connector)
Amplifier module	PCD00A-400
Operating pressure	[bar] max. 210
Fluid	Hydraulic oil according to DIN 51524 ... 51525
Fluid temperature	[°C] +20 up to max. +70
Viscosity range	[cSt] / [mm <sup>2</sup> /s] 12...230
Filtration	ISO 4406 (1999); 18/16/13
Min. pressure difference	[bar] DUR 1.6/3.2: 3; DUR 6.3/12: 5; DUR 18: 8
Hysteresis at Q <sub>nom</sub>	[%] 6
Hysteresis at Q ≤ 20 % • Q <sub>nom</sub>	[%] 6
Repeatability at ΔU <sub>set</sub> = 5 V	[%] 2

**5**

**Performance curves**

**DUR 1.6 L 06 PK\***

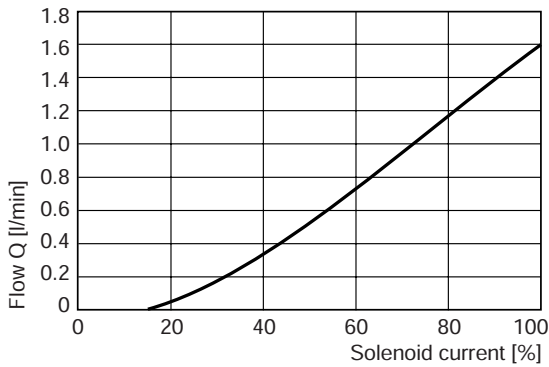

**DUR 12 L 06 PK\* / DUR 18 L 06 PK\***



**DUR 3.2 L 06 PK\* / DUR 6.3 L 06 PK\***



All characteristic curves measured with HLP46 at 50 °C.

**5**

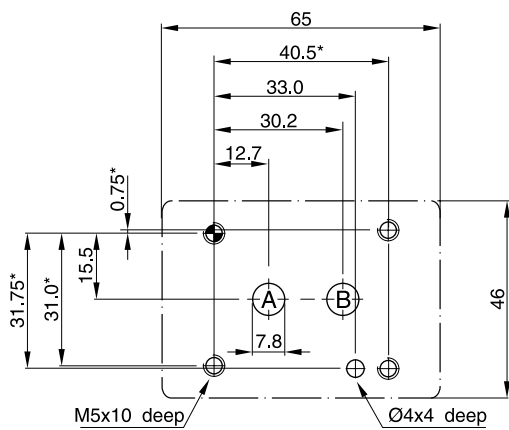
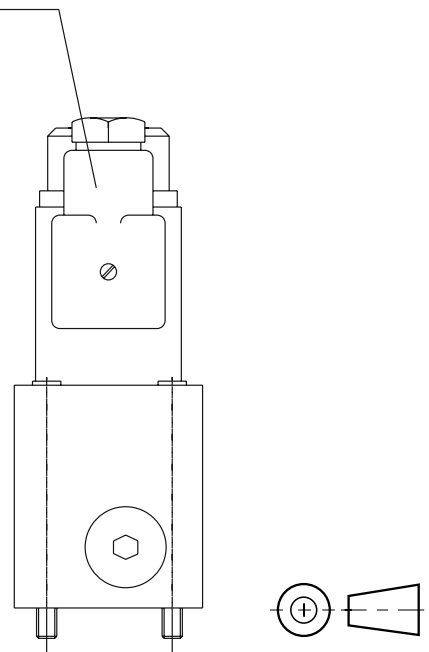
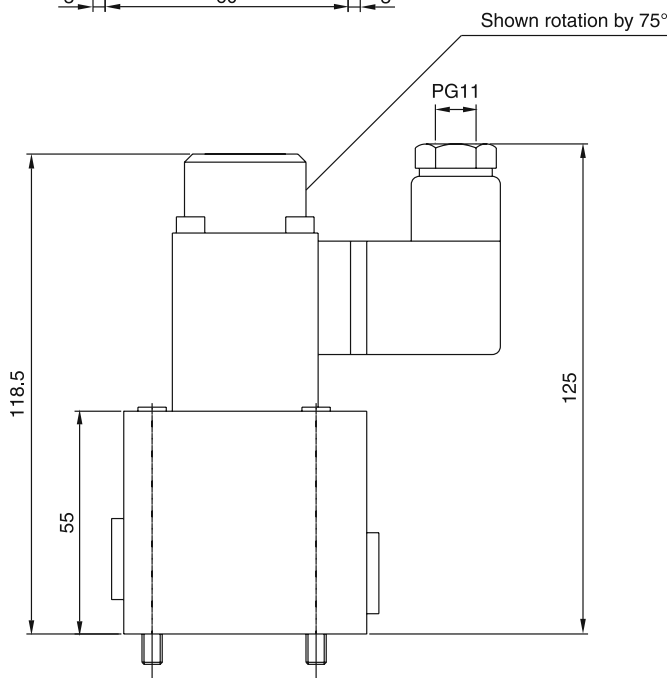
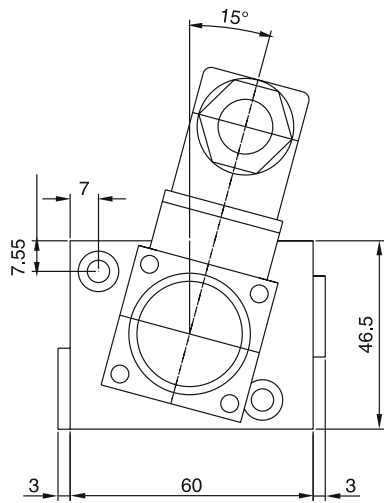

**Seal kits**

NBR	FPM
SK-DUR***L	SK-DUR***L FPM

**Sandwich rectifier plate**

If a 2 way flow control valve is used in combination with a rectifier plate the valve can be used for meter-in and meter-out flow control of an actuator.

**Design**

The intermediate rectifier plate is designed with 4 identical, symmetrically arranged check valves. Thus the differential pressure is the same in both flow directions.

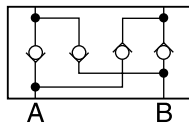

**Δp/Q-curve**

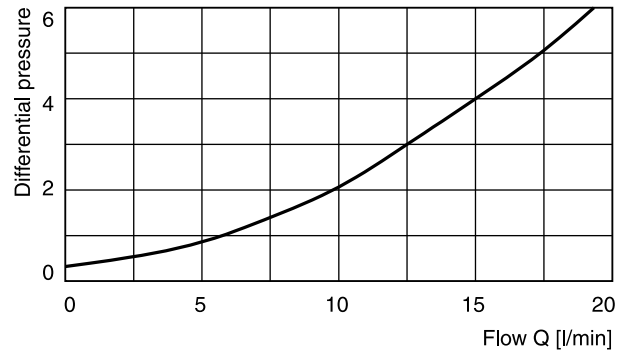

Measured with HLP46 at 50 °C.

**Dimensions**

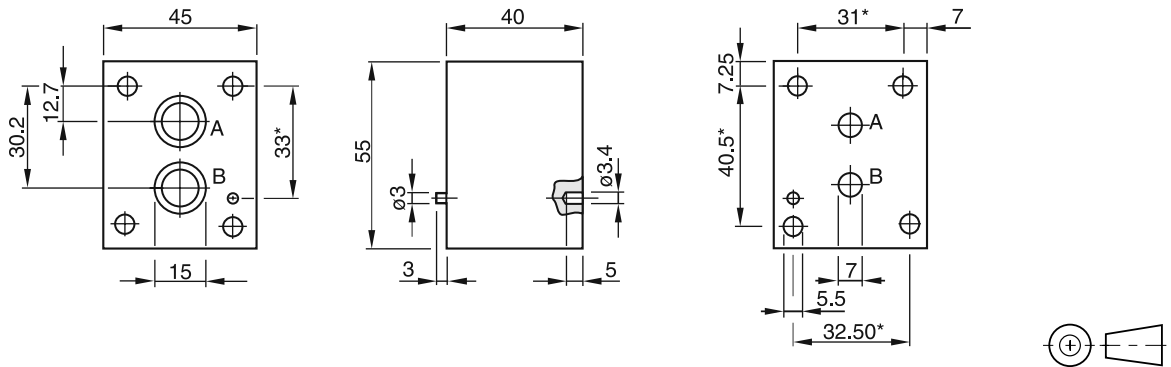

Dimension tolerances  
 \* : ± 0.1mm  
 others : ± 0.2 mm  
 holes and silhouette of valve body : untoleranced dimension

**Ordering code:** HR OA 06 C

**O-ring for sealing the connecting surface**  
 (not included)

Connections	Dimensions	required units
A, B	12 x 1.5	2

**Subplates <sup>1)</sup>**

Ordering code	
SPD 22 B 910	P, A, B and T = G1/4
SPD 23 B 910	P, A, B and T = G1/8

<sup>1)</sup> Details see chapter 12, series SPD