

Series	Description	For use with														Page		
		D*FB, D*1FB	D*FB, D*1FB OBE	D*1FH, D*1FE	D*FP, D*1FP	R4V, R6V, R4R	R4V, R6V OBE	RE06M*W	RE06M*T	VMY, VBY	DUR*L	PRPM	TDA, TEA	TDP, TPQ	RE*E*W	RE*E*T	R5V, R5R	
Amplifiers for proportional valves																		
PWD00	For valves w/o position transducer	•																11-2
PWDXX	For valves with position transducer or valves in closed loop systems	•				•	•	•	•	•	•	•			•		•	11-6
PCD00	For up to 2 single solenoid valves w/o transducer					•	•	•	•	•	•	•			•		•	11-10
Electronics for command signal processing																		
PZD00	Min/Max adjustment, 6 command channels, 6+1 ramps		•	•	•		•	•						•		•		11-14
Axis controller																		
PID00	For position, pressure and speed control in closed loop systems		•	•	•		•	•						•		•		11-18
Compax3F	Multifunctional axis controller for basic and high end applications		•		•									•				11-22
Compax3F Accessories	Terminal strips, cables, PIOs															11-36		
Accessories																		
EX-M05	Test unit for items with integrated electronics															11-40		

Characteristics / Ordering Code

Parker electronic modules PWD00A-400 for rail mounting are compact, easy to install and provide time-saving wiring by disconnectable terminals. The digital design of the circuit results in good accuracy and optimal adaption for proportional directional control valves by a comfortable interface program.

Features

The described electronic unit combines all necessary functions for the optimal operation of proportional directional control valves without position sensor (series D*FB, D*1FB). The most important features are:

- Digital circuit design
- Four parameterizable command channels
- Constant current control
- Differential input stage
- Status output
- Four-quadrant ramp function
- Enable input for solenoid driver
- Status indicator
- Parametering by serial interface RS232C
- Connection by disconnectable terminals
- Compatible to the relevant European EMC standards
- comfortable PC user software, free of charge:
www.parker.com/euro_hcd
– see "Support"

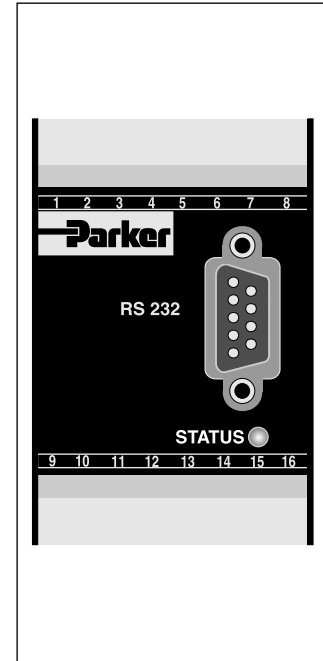
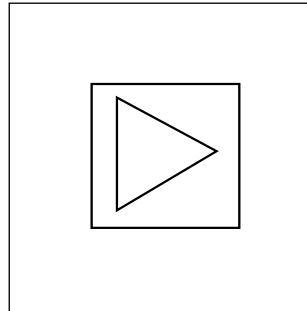

Ordering code

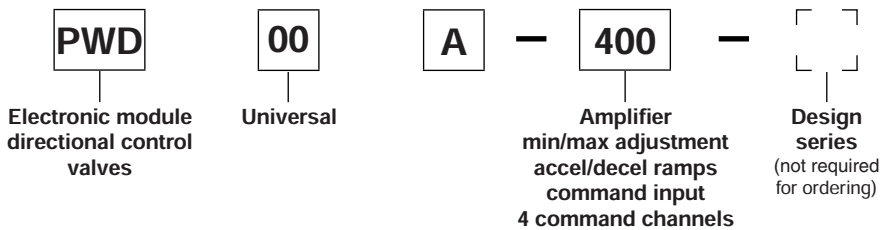

11

Technical data

General	
Model	Module package for snap-on mounting on EN 50022 rail
Package material	Polycarbonate
Inflammability class	V0 acc. UL 94
Installation position	unrestricted
Ambient temperature range	[°C] -20...+60
Protection class	IP 20 acc. EN 60529
MTTF _D value	[years] 150
Weight	[g] 160
Electrical	
Duty ratio	[%] 100
Supply voltage	[VDC] 18...30, ripple < 5 % eff., surge free ¹⁾
Current consumption max.	[A] 2.2
Pre-fusing	[A] 2.5, medium lag
Command signal	[V] +10...0...-10, ripple < 0.01 % eff., surge free, Ri = 150 kOhm
Input signal resolution	[%] 0.025
Differential input voltage max.	[V] 30 for terminals 5 und 6 against PE (terminal 8)
Enable signal	[V] 0...4.0: Off / 9.0...30: On / Ri = 30 kOhm
Command channel signal	[V] 0...4.0: Off / 9.0...30: On / Ri = 30 kOhm
Status signal	[V] 0...0.5: Off / Us: On / rated max. 15 mA
Adjustment ranges	
Min	[%] 0...50
Max	[%] 50...100
Ramp	[s] 0...32.5
Zero offset	[%] +100...-100
Current	[A] 0.8 / 1.3 / 1.8 / 2.7 / 3.5
Interface	RS 232C, DSub 9p. male for null modem cable
EMC	EN 50081-2, EN 50082-2
Connection	Screw terminals 0.2...2.5 mm ² , disconnectable
Cable specification	[mm ²] 1.5 overall braid shield for supply voltage and solenoids (AWG16)
	[mm ²] 0.5 overall braid shield for sensor and signal (AWG20)
Cable length	[m] 50

Block diagram

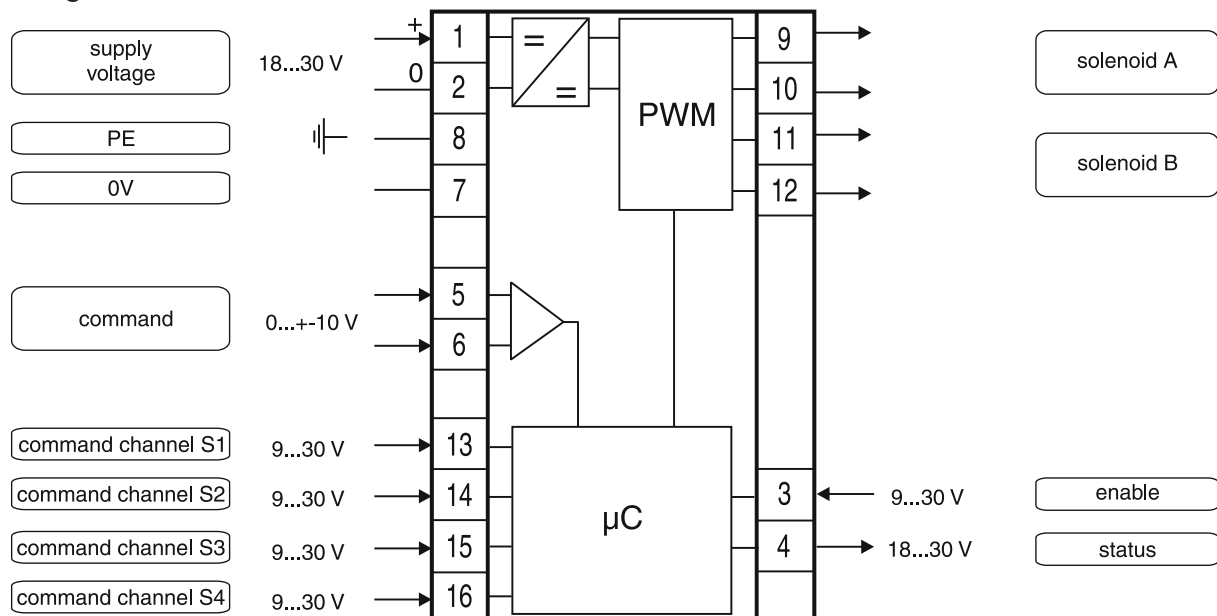

¹⁾ If solenoids with a nominal voltage of 24 V are connected, the supply voltage has to be raised to 29 V.

Signal flow diagram

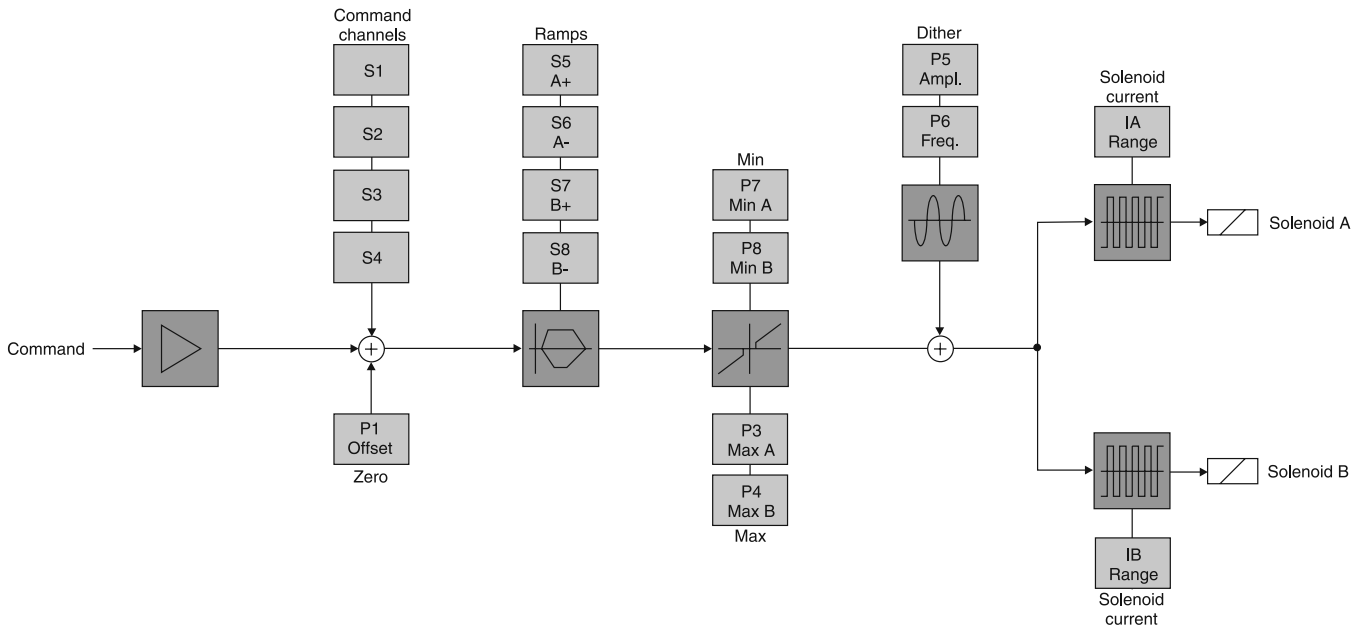

Dimensions

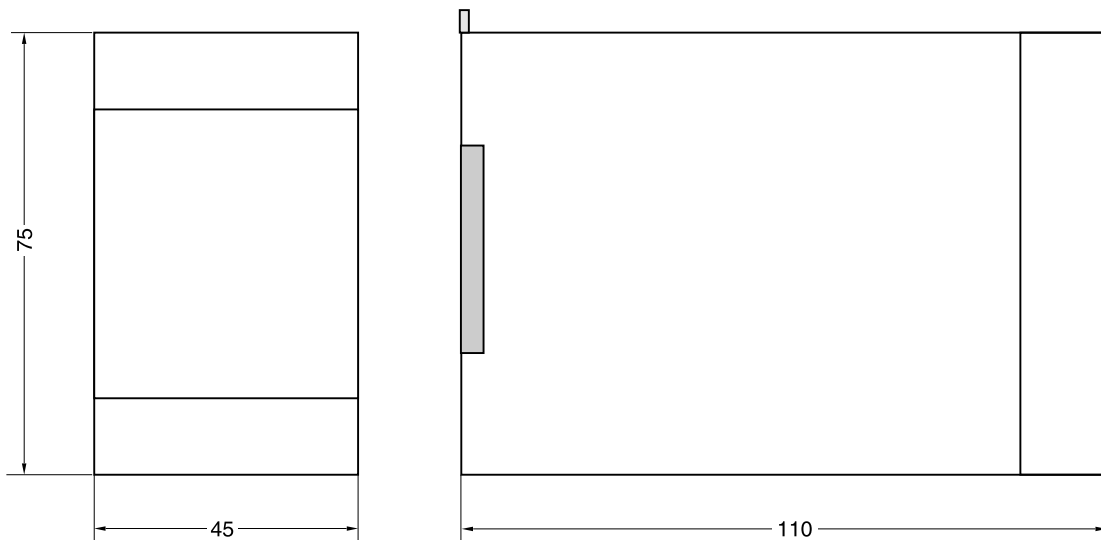

11

ProPxD interface program

The ProPxD software permits comfortable parameter setting for the module electronics. Via the clearly arranged entry mask the parameters can be monitored and modified. Storage of complete parameter sets is possible as well as printout or record as a text file for further documentation. Stored parameter sets may be loaded anytime and transmitted to other valves. Inside the electronics a nonvolatile memory stores the data with the option for recalling or modification.

The PC software can be downloaded free of charge at www.parker.com/euro_hcd – see page “Support”.

Features

- Comfortable editing of all parameters
- Depiction and documentation of parameter sets
- Storage and loading of optimized parameter adjustments
- Executable with all actual Windows® operating systems from Windows® 95 upwards
- Plain communication between PC and electronics via serial interface RS232C

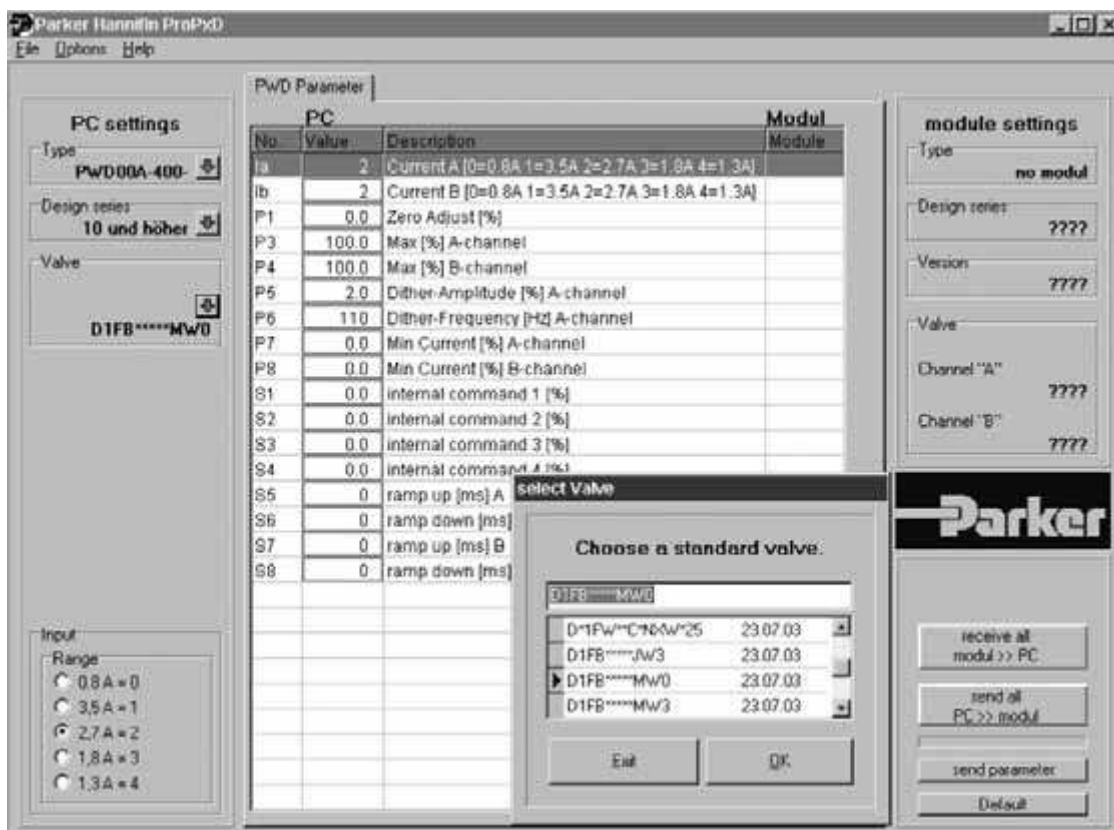

Characteristics / Ordering Code

Parker electronic modules PWDXXA-40* for rail mounting are compact, easy to install and provide time-saving wiring by disconnectable terminals. The digital design of the circuit results in good accuracy and optimal adaption for proportional directional control valves with position sensor by a comfortable interface program.

Features

The described electronic unit combines all necessary functions for the optimal operation of proportional directional control valves with position transducer or valves in closed loop systems. The most important features are:

- Digital circuit design
- Parameterizable position control of valve spool
- Constant current control
- Differential input stage with different signal options
- Monitor output for spool stroke
- Four-quadrant ramp function
- Enable input for solenoid driver
- Status indicator
- Parametering by serial interface RS232C
- Connection by disconnectable terminals
- In combination with valves without spool feedback
 - Pressure control with proportional pressure valve and pressure sensor
 - Position control with proportional DC valve and actuator position transducer
- Optional technology function "linearization"
- Comfortable PC user software, free of charge:
www.parker.com/euro_hcd
– see "Support"

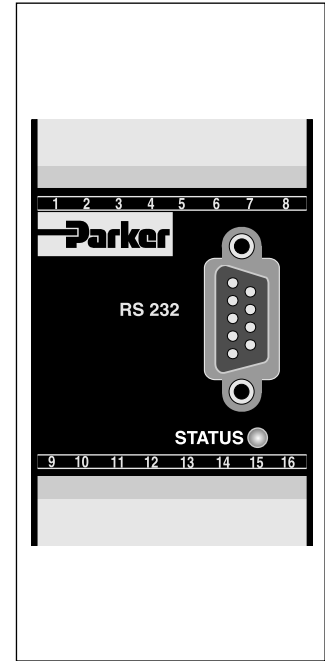
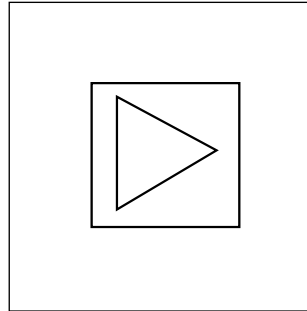

Ordering code

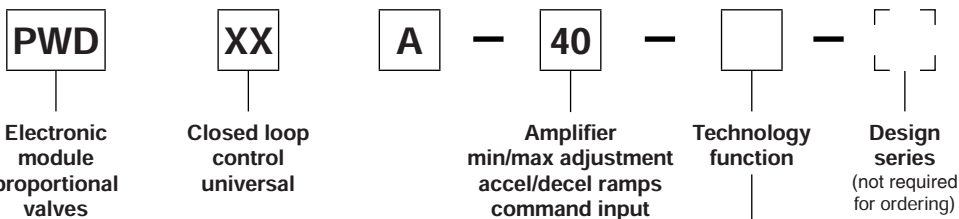

Code	Function
0	Standard
1	Linearization option

11

Technical data

General		
Model		Module package for snap-on mounting on EN 50022 rail
Package material		Polycarbonate
Inflammability class		V0 acc. UL 94
Installation position		unrestricted
Ambient temperature range	[°C]	-20...+60
Protection class		IP 20 acc. EN 60529
MTTF _D value	[years]	150
Weight	[g]	160
Electrical		
Duty ratio	[%]	100
Supply voltage	[VDC]	18...30, ripple < 5 % eff., surge free
Switch-on current typ.	[A]	22 for 0.2 ms
Current consumption max.	[A]	2.0
Pre-fusing	[A]	2.5, medium lag
Command signal options	[V] [mA] [mA]	+10...0...-10, ripple <0.01 % eff., surge free, Ri = 100 kOhm +20...0...-20, ripple <0.01 % eff., surge free, Ri = 200 Ohm 4...12...20, ripple <0.01 % eff., surge free, Ri = 200 Ohm <3.6 mA = solenoid output off, >3.8 mA = solenoid output on (acc. NAMUR NE43)
Input signal resolution	[%]	0.025
Differential input voltage max.	[V] [V]	30 for terminals 5 and 6 against PE (terminal 8) 11 for terminals 5 and 6 against 0V (terminal 2)
Sensor supply	[V]	18...30 (Us), max. current <100 mA
Enable signal	[V]	0...2.5: Off / 5...30: On / Ri = 100 kOhm
Status signal	[V]	0...0.5: Off / Us: On / rated max. 15 mA
Monitor signal	[V]	+10...0...-10, rated max. 5 mA, signal resolution 0.4 %
Adjustment ranges	Min [%] Max [%] Ramp [s] Zero offset [%] Current [A] Initial current [%]	0...50 50...100 0...32.5 +100...-100 1.3 / 2.7 / 3.5 0...25
Interface		RS 232C, DSub 9p. male for null modem cable
EMC		EN 61000-6-2
Connection		Screw terminals 0.2...2.5 mm ² , disconnectable
Cable specification	[mm ²] [mm ²]	1.5 overall braid shield for supply voltage and solenoids (AWG16) 0.5 overall braid shield for sensor and signal (AWG20)
Cable length	[m]	50
Options		
Technology function	Code1	Software adjustable transfer function with 10 compensation points for linearization of valve behaviour

Block diagram

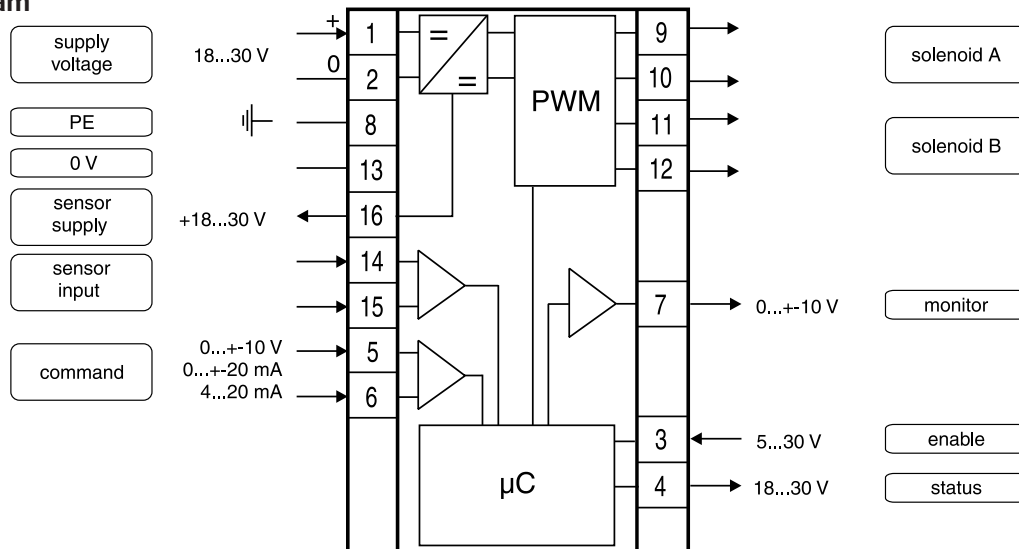

Signal flow diagram

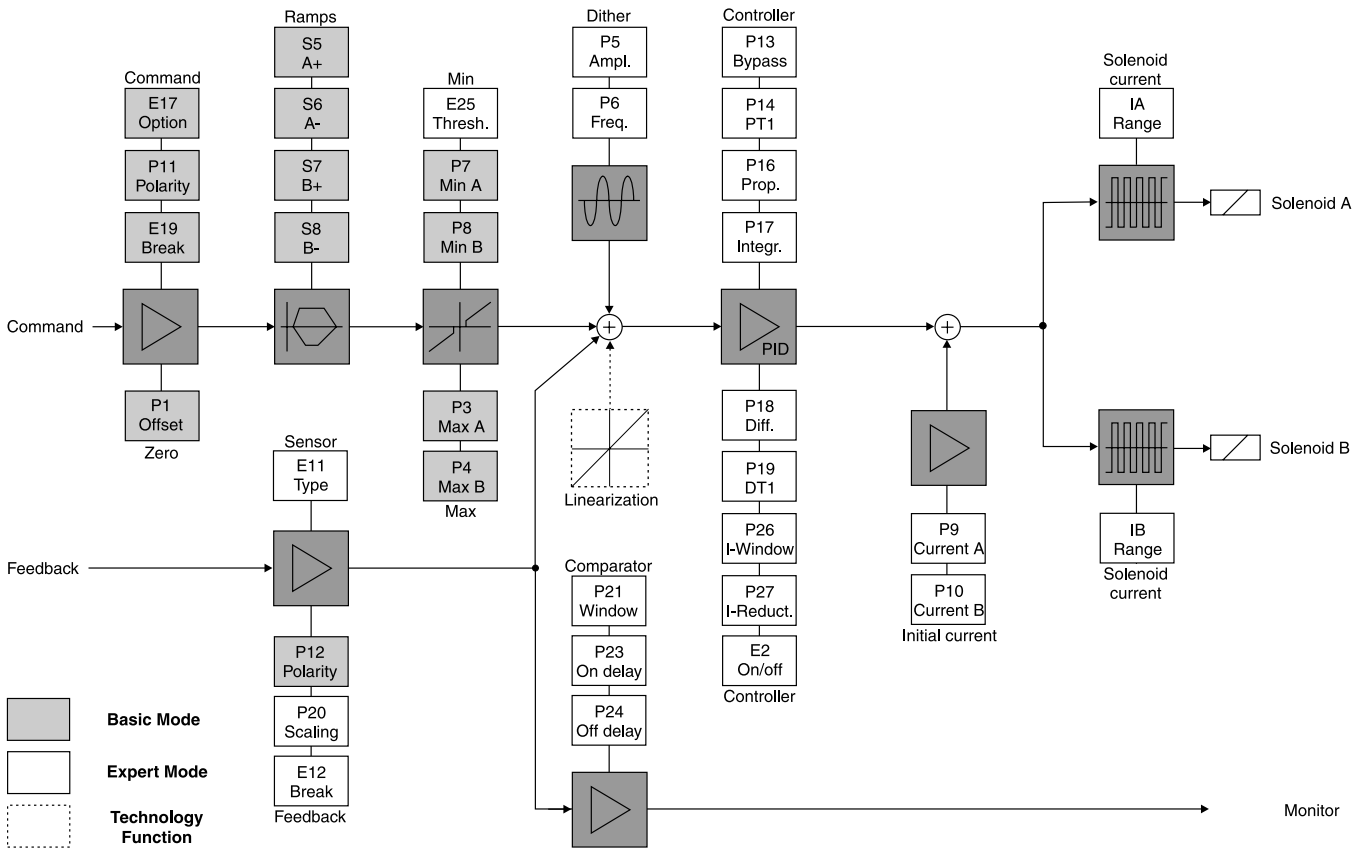

Dimensions

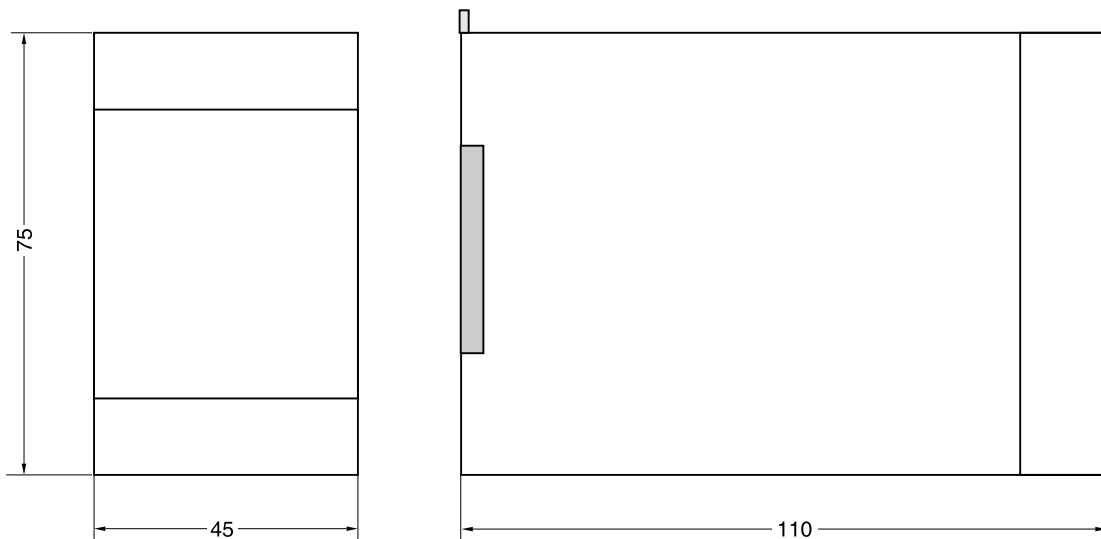

11

ProPxD interface program

The ProPxD software permits comfortable parameter setting for the module electronics. Via the clearly arranged entry mask the parameters can be monitored and modified. Storage of complete parameter sets is possible as well as printout or record as a text file for further documentation. Stored parameter sets may be loaded anytime and transmitted to other valves. Inside the electronics a nonvolatile memory stores the data with the option for recalling or modification.

The PC software can be downloaded free of charge at www.parker.com/euro_hcd – see page “Support”.

Features

- Comfortable editing of all parameters
- Depiction and documentation of parameter sets
- Storage and loading of optimized parameter adjustments
- Executable with all actual Windows® operating systems from Windows® 95 upwards
- Plain communication between PC and electronics via serial interface RS232C

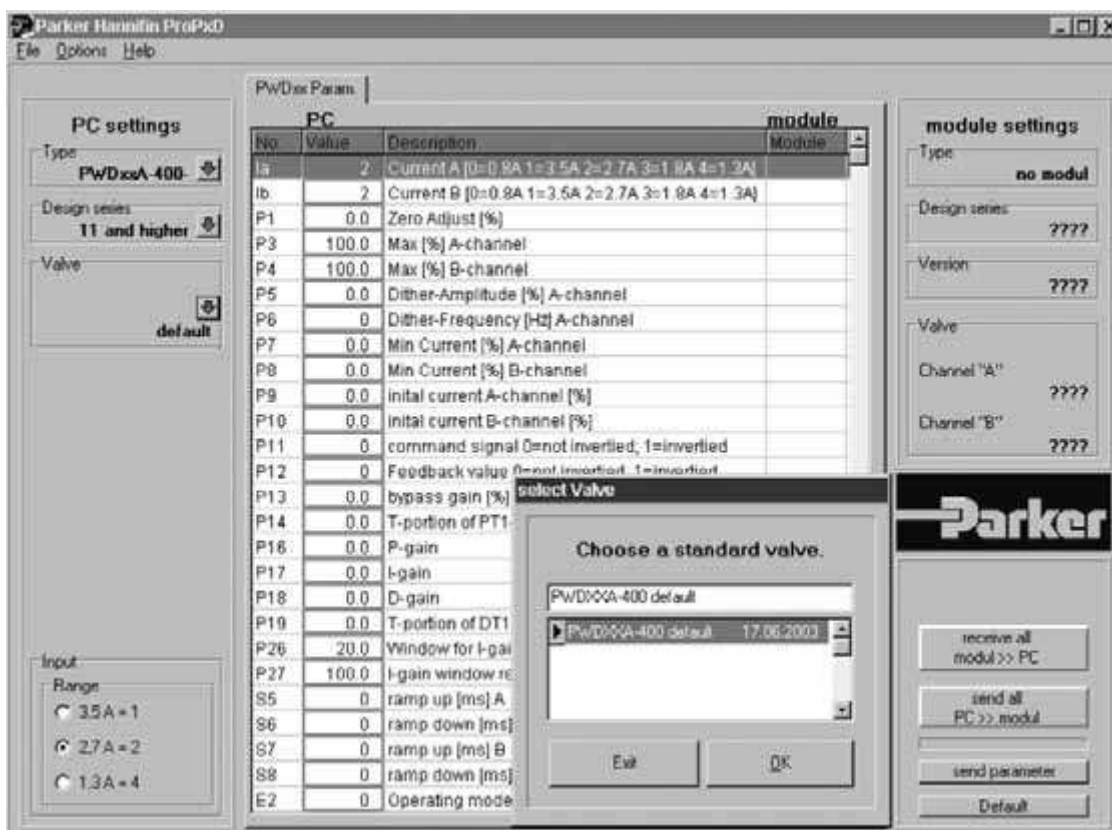

Characteristics / Ordering Code

Parker electronic modules series PCD00A-400 for rail mounting are compact, easy to install and provide time-saving wiring by disconnectable terminals. The digital design of the circuit results in good accuracy and optimal adaption for proportional pressure/flow control valves by a comfortable interface program.

Features

The described electronic unit combines all necessary functions for the optimal operation of two proportional pressure/flow control valves (series R*V, RE*E*W, RE06M*W, DUR, PRPM, VBY, VMY, TDA, TEA).

The most important features are:

- Digital circuit design
- Two independent operable amplifiers
- Four parameterizable command channels
- Constant current control
- Two input stages 0...10 V
- Status output
- Two up/down ramp functions
- Enable input for solenoid driver
- Status indicator
- Parametering by serial interface RS232C
- Connection by disconnectable terminals
- Compatible to the relevant European EMC standards
- Comfortable PC user software, free of charge:
www.parker.com/euro_hcd
– see "Support"

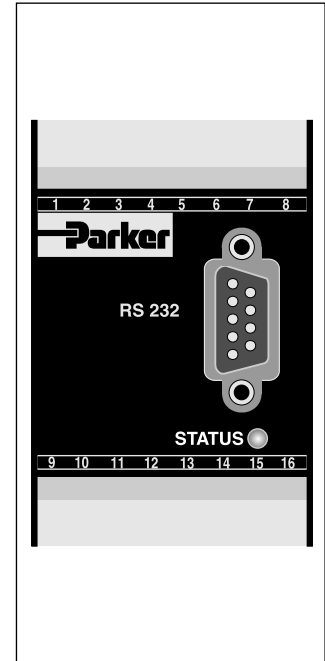
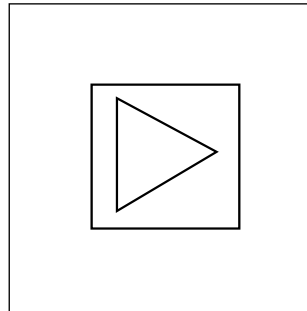

Ordering code

11

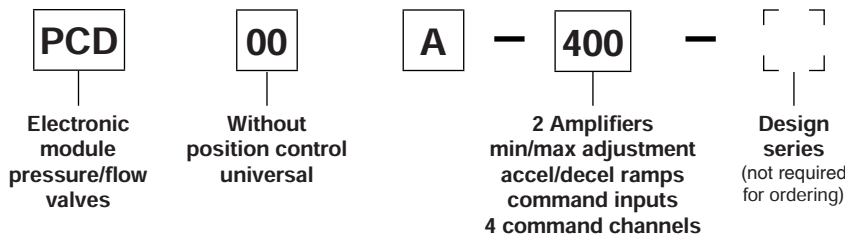

Technical data

General		
Model	Module package for snap-on mounting on EN 50022 rail	
Package material	Polycarbonate	
Inflammability class	V0 acc. UL 94	
Installation position	unrestricted	
Ambient temperature range	[°C]	-20...+60
Protection class	IP 20 acc. EN 60529	
MTTF _D value	[years]	150
Weight	[g]	160
Electrical		
Duty ratio	[%]	100
Supply voltage	[VDC]	18...30, ripple < 5 % eff., surge free ¹⁾
Current consumption max.	[A]	5.0
Pre-fusing	[A]	6.3, medium lag
Command signal	[V]	0...+10, ripple < 0.01 % eff., surge free, Ri = 150 kOhm
Input signal resolution	[%]	0.025
Differential input voltage max.	[V]	30 for terminals 5 und 6 against PE (terminal 8)
Enable signal	[V]	0...4.0: Off / 9.0...30: On / Ri = 30 kOhm
Command channel signal	[V]	0...4.0: Off / 9.0...30: On / Ri = 30 kOhm
Status signal	[V]	0...0.5: Off / Us: On / rated max. 15 mA
Adjustment ranges	Min [%] Max [%] Ramp [s] Current [A]	0...50 50...100 0...32.5 0.8 / 1.3 / 1.8 / 2.7 / 3.5
Interface	RS 232C, DSub 9p. male for null modem cable	
EMC	EN 50081-2, EN 50082-2	
Connection	Screw terminals 0.2...2.5 mm ² , disconnectable	
Cable specification	[mm ²]	1.5 overall braid shield for supply voltage and solenoids (AWG16)
	[mm ²]	0.5 overall braid shield for sensor and signal (AWG20)
Cable length	[m]	50

Block diagram

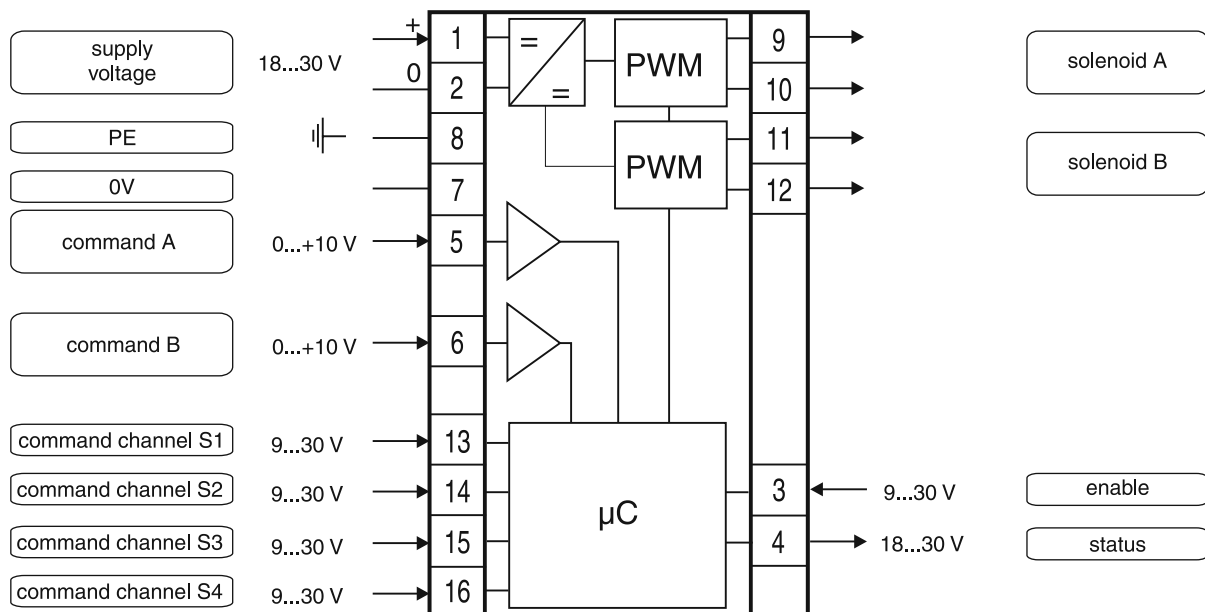

¹⁾ If solenoids with a nominal voltage of 24 V are connected, the supply voltage has to be raised to 29 V.

Signal flow diagram

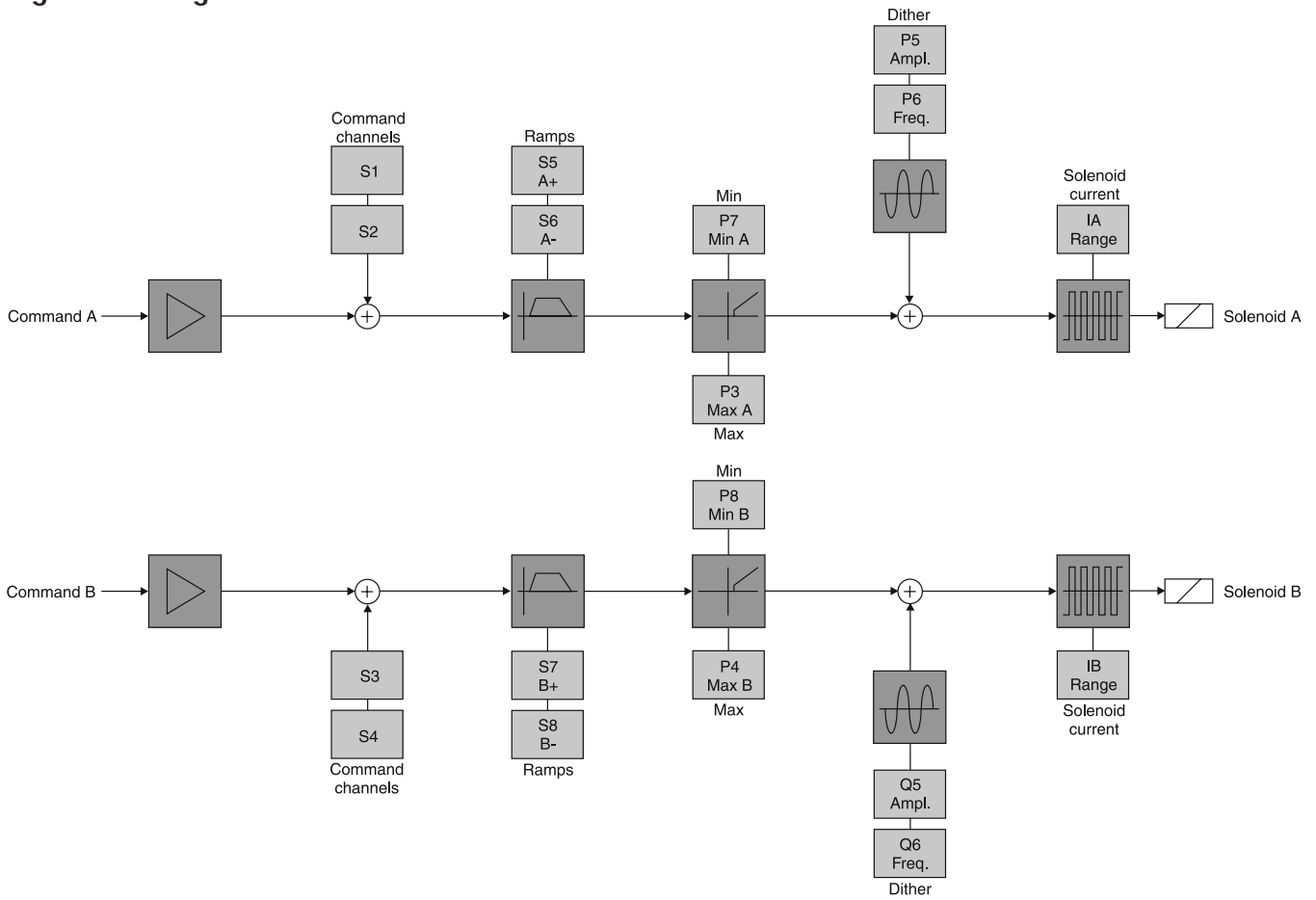

Dimensions

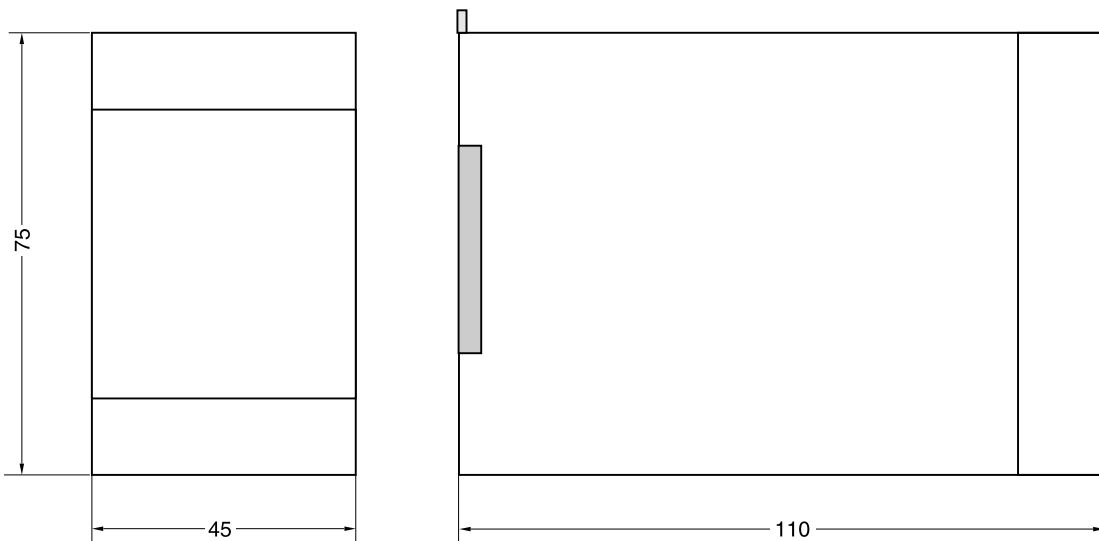

11

ProPxD interface program

The ProPxD software permits comfortable parameter setting for the module electronics. Via the clearly arranged entry mask the parameters can be monitored and modified. Storage of complete parameter sets is possible as well as printout or record as a text file for further documentation. Stored parameter sets may be loaded anytime and transmitted to other valves. Inside the electronics a nonvolatile memory stores the data with the option for recalling or modification.

The PC software can be downloaded free of charge at www.parker.com/euro_hcd – see page “Support”.

Features

- Comfortable editing of all parameters
- Depiction and documentation of parameter sets
- Storage and loading of optimized parameter adjustments
- Executable with all actual Windows® operating systems from Windows® 95 upwards
- Plain communication between PC and electronics via serial interface RS232C

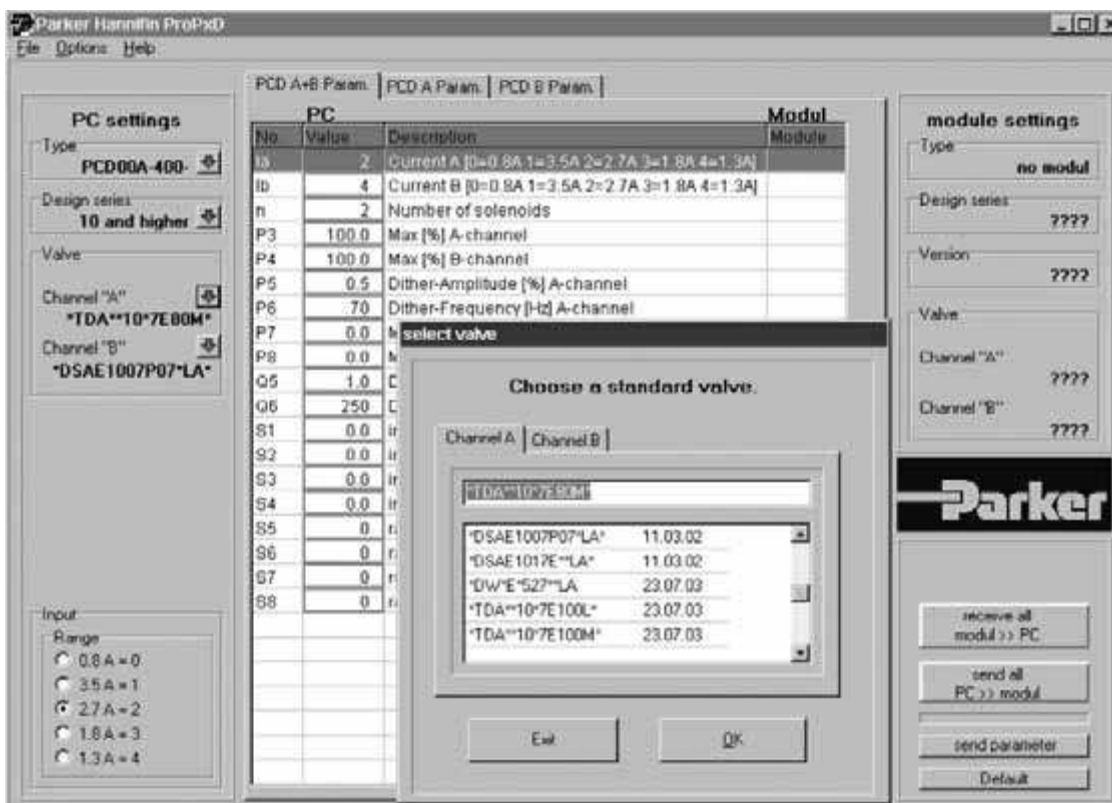

Characteristics / Ordering Code

Parker electronic modules PZD00A-40* for rail mounting are compact, easy to install and provide time-saving wiring by disconnectable terminals. The digital design of the circuit results in good accuracy and optimal adaption for command signal processing by a comfortable interface program. The electronic unit may be connected in series to proportional valves with onboard electronic as well as to amplifier modules P*D.

Features

- Digital circuit design
- Six parameterizable command channels with optional additive or priority dependent signal processing
- Output stage with different signal options
- Input stage with different signal options
- Status output
- Four-quadrant ramp function
- Reference output for potentiometer supply
- Status indicator
- Parametering by serial interface RS232C
- Connection by disconnectable terminals
- Compatible to the relevant European EMC standards
- Optional technology function "linearization"
- Comfortable PC user software, free of charge:
www.parker.com/euro_hcd
– see "Support"

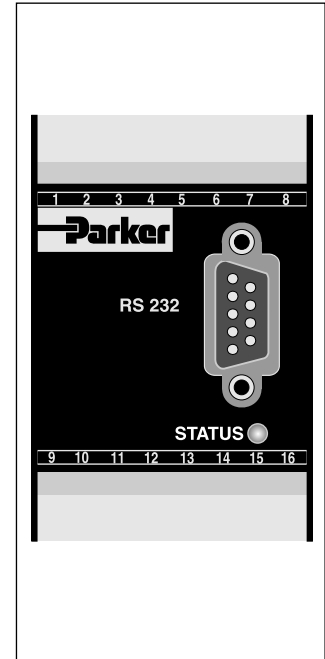
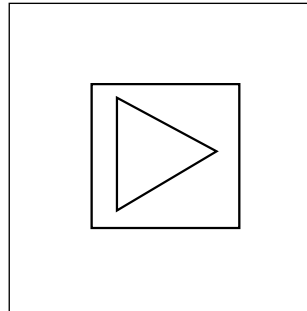

Ordering code

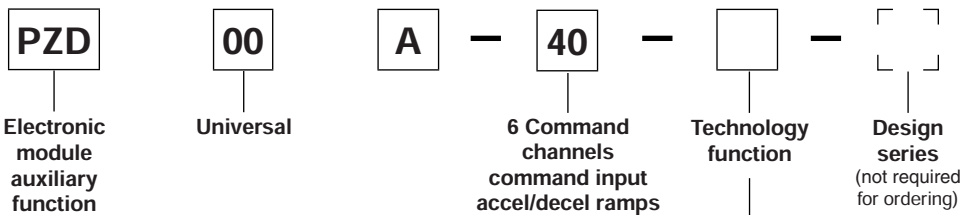

Code	Function
0	Standard
1	Linearization option

11

Technical data

General	
Model	Module package for snap-on mounting on EN 50022 rail
Package material	Polycarbonate
Inflammability class	V0 acc. UL 94
Installation position	unrestricted
Amb. temperature range	[°C] -20...+60
Protection class	IP 20 acc. EN 60529
MTTF _D value	[years] 150
Weight	[g] 160
Electrical	
Duty ratio	[%] 100
Supply voltage	[VDC] 18...30, ripple < 5 % eff., surge free
Current consumption max.	[mA] 100
Pre-fusing	[mA] 500 medium lag
Command signal options	[V] +10...0...-10, ripple <0.01 % eff., surge free, Ri = 100 kOhm [mA] +20...0...-20, ripple <0.01 % eff., surge free, Ri = 200 Ohm [mA] 4...12...20, ripple <0.01 % eff., surge free, Ri = 200 Ohm <3.6 mA = output signal 0 V / 0 mA / 12 mA acc. to output option >3.8 mA = output signal on (acc. NAMUR NE43)
Input signal resolution	[%] 0.025
Differential input max.	[V] 30 for terminals 5 und 6 against PE (terminal 8)
Command channel signal	[V] 0...1.0: Off / 5...30: On / Ri = 100 kOhm
Status signal	[V] 0...0.5: Off / Us: On / rated max. 15 mA
Output signal options	[V] +10...0...-10, rated max. 15 mA [mA] +20...0...-20, Ro < 500 Ohm [mA] 4...12...20, Ro < 500 Ohm
Output signal resolution	[%] 0.025
Reference output	[V] +10 / -10, 2 %, rated max. 15 mA
Adjustment ranges	Min [%] 0...50 Max [%] 50...100 Cmd channels [%] +100...-100 Ramp [s] 0...32.5 Zero offset [%] +100...-100
Interface	RS 232C, DSub 9p. male for null modem cable
EMC	EN 50081-2, EN 50082-2
Connection	Screw terminals 0.2...2.5 mm ² , disconnectable
Cable specification	[mm ²] 0.5 overall braid shield (AWG20)
Cable length	[m] 50
Options	
Technology function	Code1 Software adjustable transfer function with 10 compensation points for linearization of valve behaviour

Block diagram

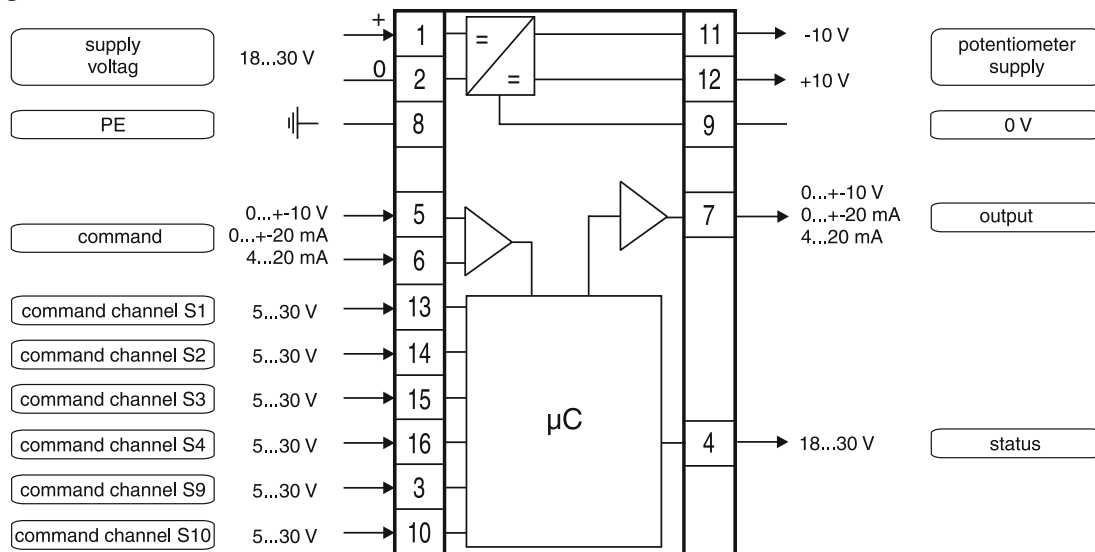

Signal flow diagram

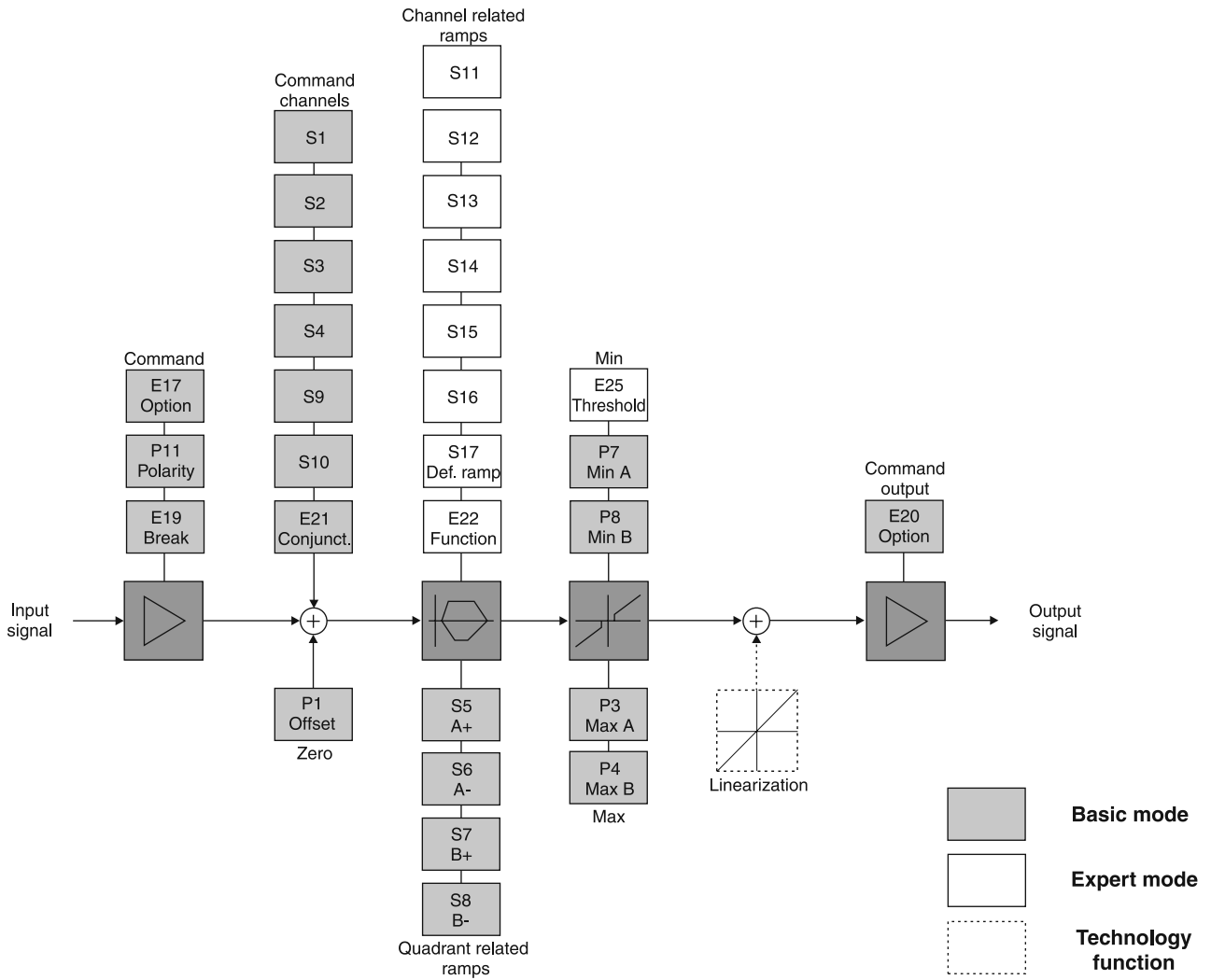

Dimensions

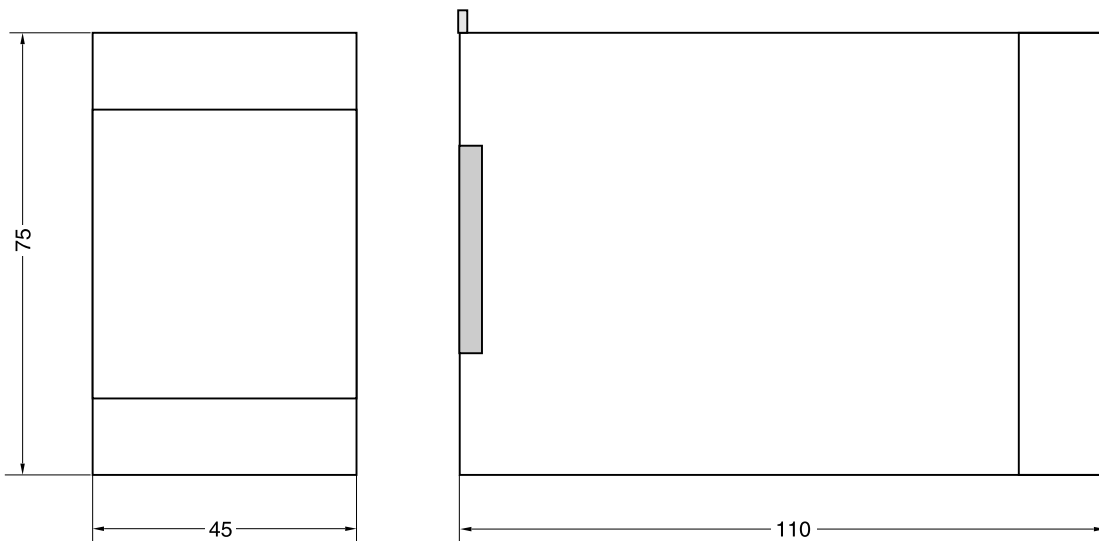

11

ProPxD interface program

The ProPxD software permits comfortable parameter setting for the module electronics. Via the clearly arranged entry mask the parameters can be monitored and modified. Storage of complete parameter sets is possible as well as printout or record as a text file for further documentation. Stored parameter sets may be loaded anytime and transmitted to other valves. Inside the electronics a nonvolatile memory stores the data with the option for recalling or modification.

The PC software can be downloaded free of charge at www.parker.com/euro_hcd – see page “Support”.

Features

- Comfortable editing of all parameters
- Depiction and documentation of parameter sets
- Storage and loading of optimized parameter adjustments
- Executable with all actual Windows® operating systems from Windows® 95 upwards
- Plain communication between PC and electronics via serial interface RS232C

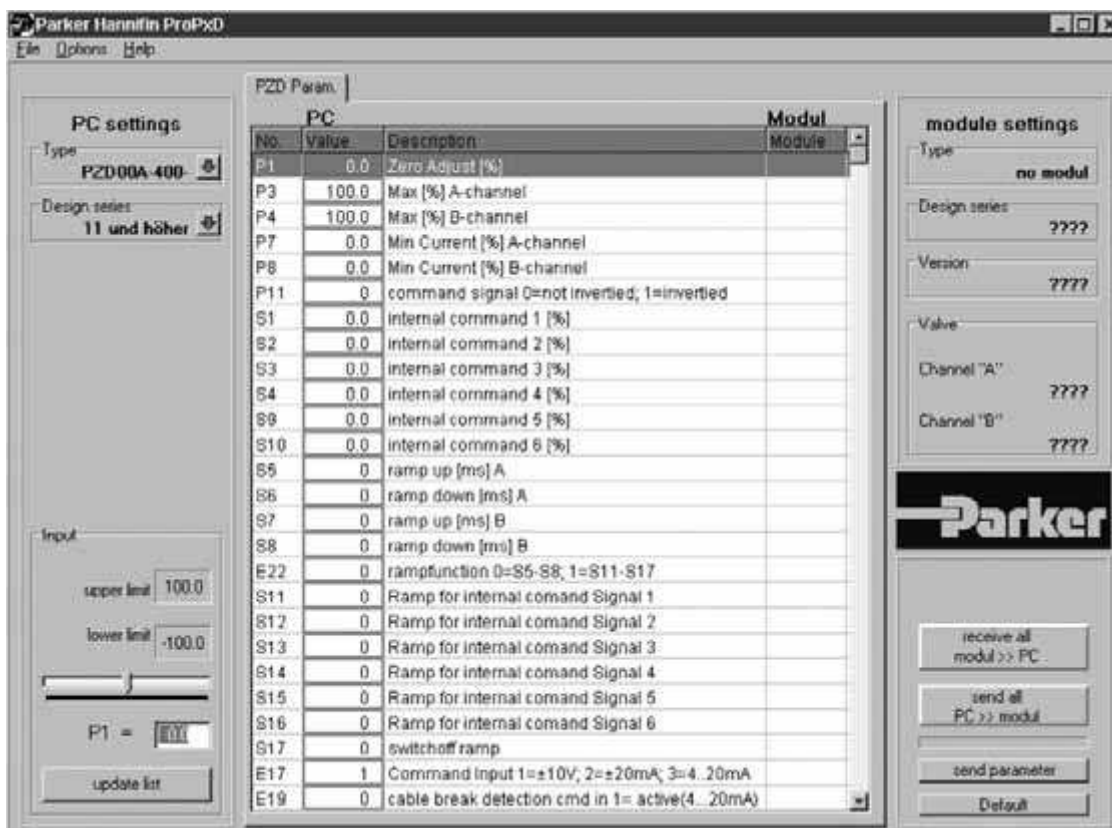

Characteristics / Ordering Code

Parker electronic modules PID00A-40* for rail mounting are compact, easy to install and provide time-saving wiring by disconnectable terminals. The digital design of the circuit results in good accuracy and optimal adaption for closed loop controls by a comfortable interface program.

Features

The described electronic unit combines all necessary functions for the optimal operation of closed loop controls. The most important features are:

- Extended PID controls
- Speed control with position feedback
- Differential input stage with different signal options
- Output stage with different output options
- Four-quadrant ramp function
- Status indicator
- Digital circuit design
- Parametering by serial interface RS232C
- Connection by disconnectable terminals
- Compatible to the relevant European EMC standards
- Optional technology function "linearization"
- Comfortable PC user software, free of charge:
www.parker.com/euro_hcd
– see "Support"

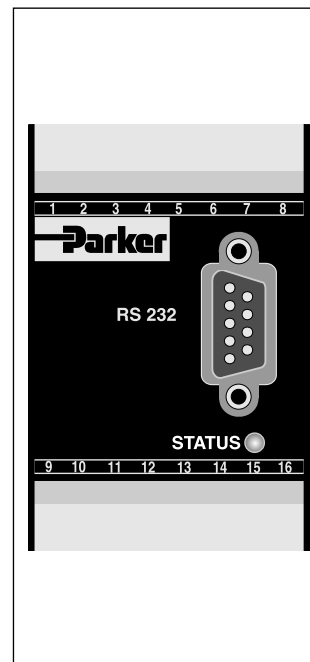
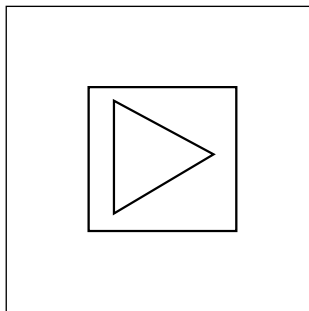

Ordering code

11

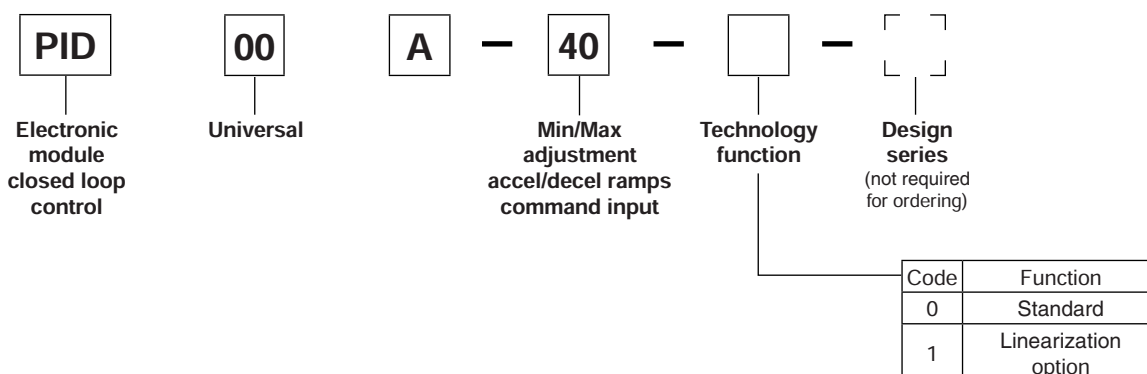

Technical data

General			
Model		Module package for snap-on mounting on EN 50022 rail	
Package material		Polycarbonate	
Inflammability class		V0 acc. UL 94	
Installation position		unrestricted	
Ambient temperature range	[°C]	-20...+60	
Protection class		IP 20 acc. EN 60529	
MTTF _D value	[years]	150	
Weight	[g]	160	
Electrical			
Duty ratio	[%]	100	
Supply voltage	[VDC]	18...30, ripple < 5 % eff., surge free	
Current consumption max.	[mA]	100	
Pre-fusing	[mA]	500	
Command signal options	[V]	+10...0...-10, ripple <0.01 % eff., surge free, Ri = 100 kOhm	
	[mA]	+20...0...-20, ripple <0.01 % eff., surge free, Ri = 200 Ohm	
	[mA]	4...12...20, ripple <0.01 % eff., surge free, Ri = 200 Ohm	
		<3.6 mA = solenoid output off, >3.8 mA = solenoid output on (acc. NAMUR NE43)	
Input signal resolution	[%]	0.025	
Differential input voltage max.	[V]	30 for terminals 5 und 6 against PE (terminal 8)	
Enable signal	[V]	0...1: Off / 5...30: On / Ri = 100 kOhm	
Status signal	[V]	0...0.5: Off / Us: On / rated max. 15 mA	
Monitor signal	[V]	+10...0...-10, rated max. 5 mA, signal resolution 0.4 %	
Output signal options	[V]	+10...0...-10, rated max. 15 mA	
	[mA]	+20...0...-20, Ro < 500 Ohm	
	[mA]	+50...0...-50, Ro < 200 Ohm	
	[mA]	4...12...20, Ro < 500 Ohm	
Output signal resolution	[%]	0.025	
Potentiometer supply	[V]	+10...0...-10 2 %, rated max. 15 mA	
Sensor supply	[V]	18...30 (Us), rated max. 100 mA	
Adjustment ranges	Min	[%]	0...50
	Max	[%]	50...100
	Ramp	[s]	0...32.5
	Zero offset	[%]	+100...-100
Interface		RS 232C, DSub 9pole male for null modem cable	
EMC		EN 50081-2, EN 50082-2	
Connection		Screw terminals 0.2...2.5 mm ² , disconnectable	
Cable specification	[mm ²]	0.5 overall braid shield (AWG20)	
Cable length	[m]	50	
Options			
Technology function	Code1	Software adjustable transfer function with 10 compensation points for linearization of valve behaviour	

Block diagram

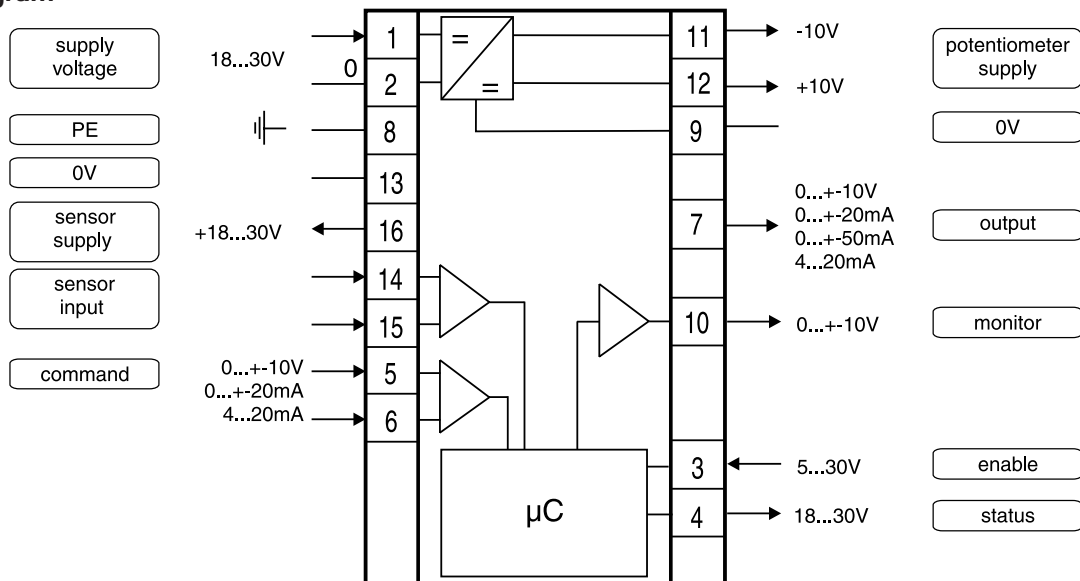

Signal flow diagram

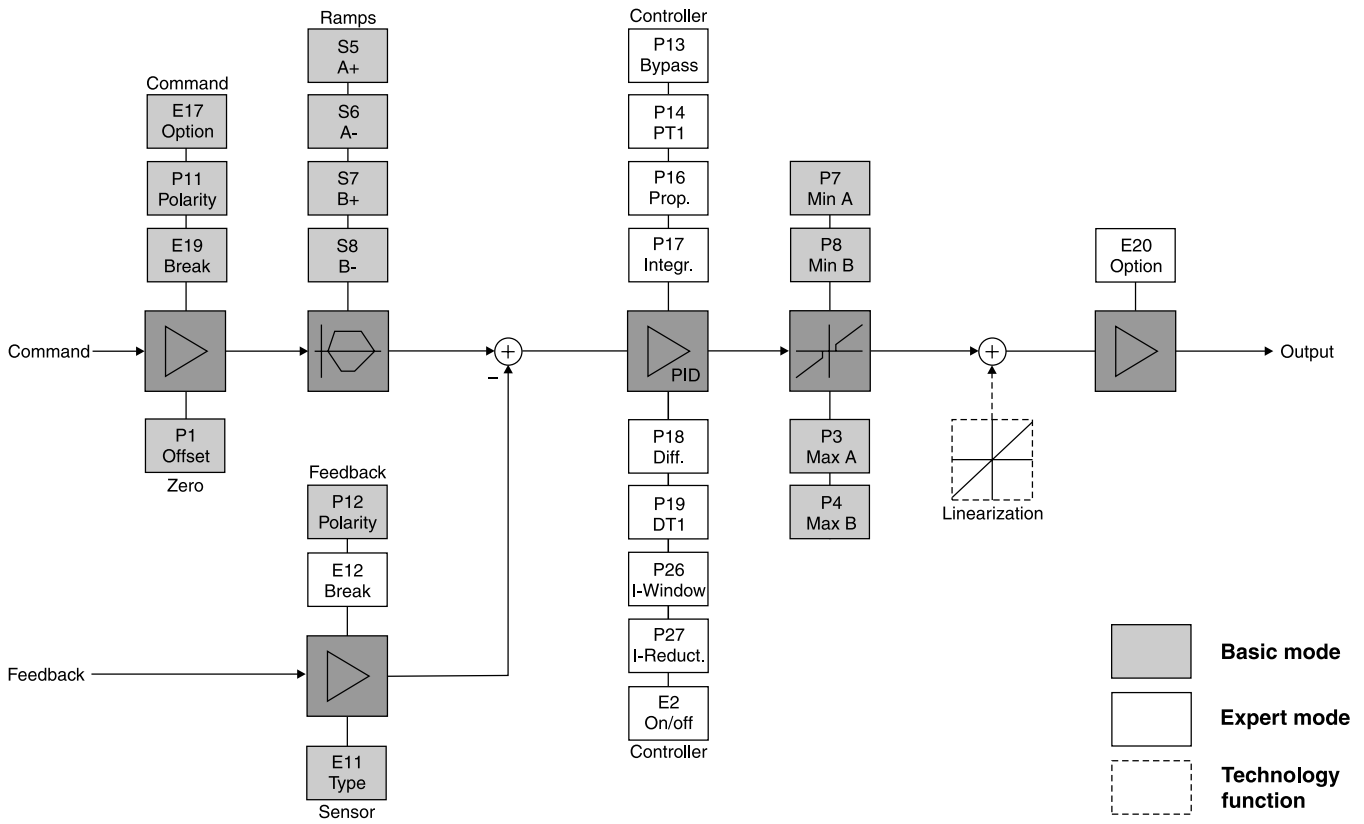

Dimensions

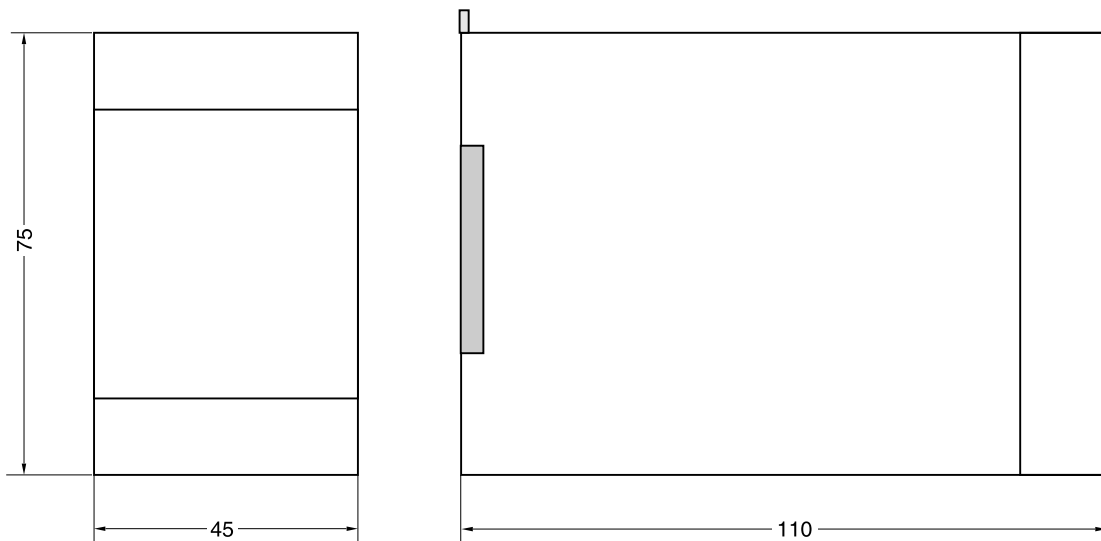

11

ProPxD interface program

The ProPxD software permits comfortable parameter setting for the module electronics. Via the clearly arranged entry mask the parameters can be monitored and modified. Storage of complete parameter sets is possible as well as printout or record as a text file for further documentation. Stored parameter sets may be loaded anytime and transmitted to other valves. Inside the electronics a nonvolatile memory stores the data with the option for recalling or modification.

The PC software can be downloaded free of charge at www.parker.com/euro_hcd – see page “Support”.

Features

- Comfortable editing of all parameters
- Depiction and documentation of parameter sets
- Storage and loading of optimized parameter adjustments
- Executable with all actual Windows® operating systems from Windows® 95 upwards
- Plain communication between PC and electronics via serial interface RS232C

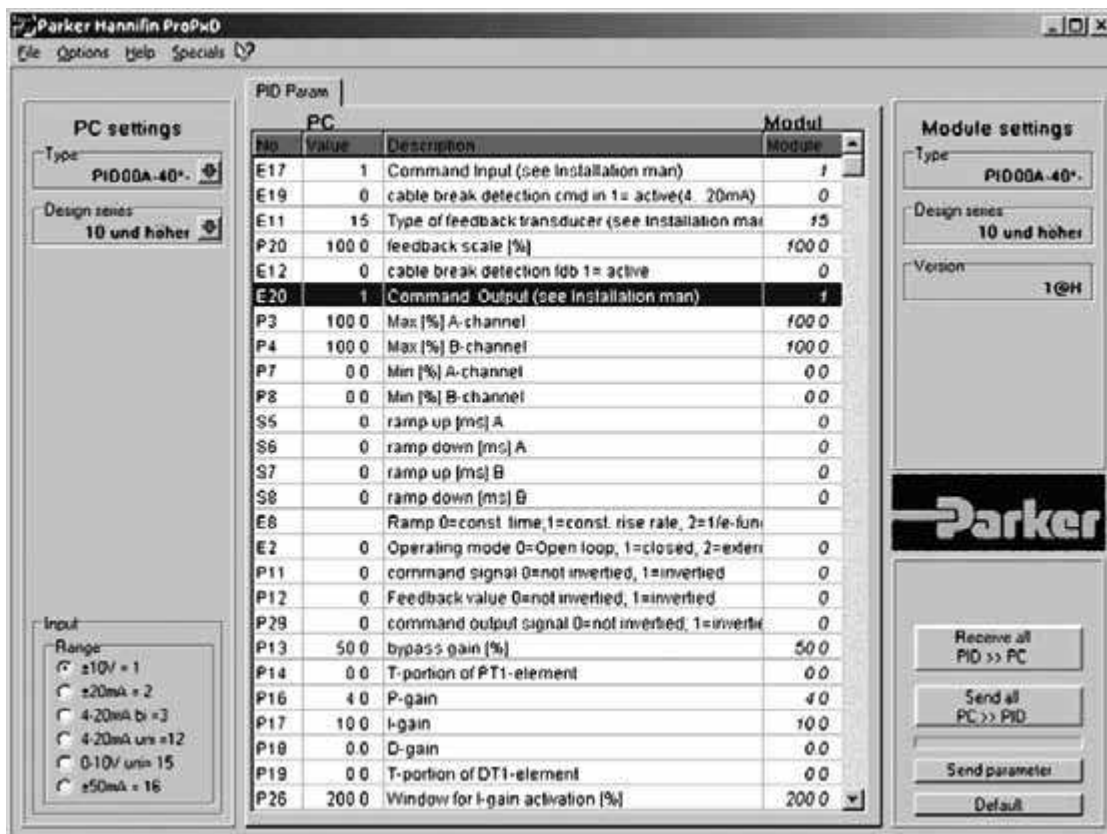

The Compax3F is a part of the servo drive family of Parker Hannifin. It is especially designed for the requirements of electrohydraulic systems and in particular for position and force control of electrohydraulic axis.

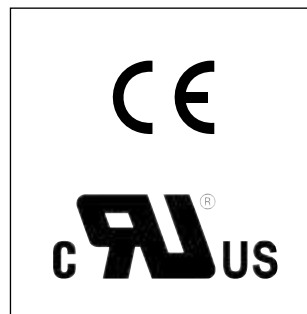

Attention:

For application support and customized software, please contact your local Parker representative.

Large drive range

- Valves:
 - Proportional direction control valves
 - Proportional pressure relief- and pressure reducing valves
 - Flow valves
- Drives:
 - Cylinders
 - Rotary drives
 - Motors

Range of application

- Closed loop position and force control of linear cylinders and rotary drives
- Switching between position and force control
- Synchronous run with up to 64 axes

Typical applications

- Feeder axis
- Position and force control of press cylinders in material forming machines
- Roller clearance control in roller presses
- Die casting machines
- Custom-designed software packages on request

Ordering Code



Code	Interface	T11	T30	T40
I11	Digital inputs/outputs		•	•
I12	Digital inputs/outputs	•		
I20	Profibus DP V0/V1/V2 (12 Mbit/s)	•	•	•
I21	CANopen		•	•
I22	DeviceNet		•	•
I30	PowerLink		•	•
I31	EtherCAT		•	•
I32	Profinet	•	•	•

Code	Options
M00	Standards
M10	Extension 12 digital I/Os & HEDA (motion bus)
M11	HEDA (motionbus)
M12	Extension 12 digital I/Os

Code	Technology functions
T11	Positioning/pressure and force control
T30	Programmable motion control according to IEC61131
T40	Electronic Cam

Connection set for Compax3F included in delivery.

Complete kit with mating plug connectors (X1, X2 and X3) for Compax3 connectors, special shield connecting terminal and snap-on foot for mounting rail

11

Function	Motion control with motion profiles. Suitable for position and force/pressure control
Housing / protection class	closed metal housing, isolation according to VDE 0160 / IP 20
Supply voltage [VDC]	21...27 VDC, ripple <1VSS
Current requirements [A]	0,8 for the device, digital outputs 100 mA each
Supported feedback-systems	<ul style="list-style-type: none"> • Analog 0..20 mA, 4..20 mA, ±10 V • Start-Stop-Interface • SSI-Interface • EnDat2.1-Interface • 1VSS (max. 400 kHz) Interface, 13.5 Bit / Distance coding • TTL (RS422) (max. 5 MHz), internal post-quadrature resolution
Set point generator	<ul style="list-style-type: none"> • Jerk-limited ramps • Travel data in increments, mm, inches or variable by scale factor • Specification of speed, acceleration, delay and jerk factor • Force/pressure inputs in N, psi, etc. variable by scale factor
Monitoring functions	<ul style="list-style-type: none"> • Power/auxiliary supply range • Following error monitoring • Hard- and Software switches
Inputs and Outputs	<ul style="list-style-type: none"> • 8 control inputs: 24 VDC / 10 kOhm • 4 control inputs Active HIGH / short-circuit protected / 24 V / 100 mA • 4 analog current input (14 Bit) • 2 analog voltage input (14 Bit) • 4 analog output (16 Bit, current or voltage) switchable in pairs
RS232 / RS485 (switchable) RS232:	<ul style="list-style-type: none"> • 115200 Baud • Word length 8 bits, 1 start bit, 1 stop bit • Hardware handshake XON, XOFF
RS485 (2 or 4-wire):	<ul style="list-style-type: none"> • 9600, 19200, 38400, 57600 or 115200 Baud • Word length 7/8 Bit, 1 Start-, 1 Stop bit • Parity (switchable) even/odd
Bus systems	<ul style="list-style-type: none"> • Profibus DP V0-V2 (I20), 12 Mbit/s, PROFIdrive-Profil Drive technology • CANopen (CiADS402) (I21) • DeviceNet (I22) • PowerLink (I30) • EtherCAT (I31) • Profinet (I32)
CE Compliance	<ul style="list-style-type: none"> • EMC interference emission/limit values for industrial utilization according to EN61 800-3 first environment (commercial and residential area), class A via integrated mains filter for up to 10mCable length, otherwise with external mains filter • EMC immunity/limit values for industrial utilization according to EN61 800-3
Insulation requirements	<ul style="list-style-type: none"> • Protection class I according to EN 50178 (VDE 0160 part 1) • Contact protection: according to DIN VDE 0106, part 100 • Overvoltage: Voltage class III according to HD 625 (VDE 0110-1) • Degree of contamination 2 according to HD 625 (VDE 0110 part 1) and EN 50178 (VDE 0160 part 1)
Environmental conditions General environmental conditions acc. to EN 60 721-3-1 to 3-3	<ul style="list-style-type: none"> • Climate (temperature / humidity / barometric pressure) • Class 3K3
Permissible ambient temperature	<ul style="list-style-type: none"> • Operation: 0 to +45 °C class 3K3 • Storage: -25 to +70 °C class 2K3 • Transport: -25 to +70 °C class 2K3
Tolerated humidity: non condensing	<ul style="list-style-type: none"> • Operation: ≤ 85 % class 2K3 • Storage: ≤ 95 % class 3K3 (relative humidity) • Transport: ≤ 95 % class 2K3
Elevation of operating site: ≤1000 m above sea level for 100 % load ratings	<ul style="list-style-type: none"> • Please inquire for greater elevations • Protection class IP20 according EN 60 529
EMC directives and harmonised EC norms	<ul style="list-style-type: none"> • EC low voltage directive 73/23/EEC and RL 93/68/EEC: EN 50 178, General industrial safety norm Equipping electric power systems with electronic operating equipment HD 625, general electrical safety. Insulation principles for electrical operating equipment EN 60 204-1, Machinery norm, partly applied • EC-EMC directive 89/336/EEC: EN 61 800-3, EMC norm Product standard for variable speed drives EN 50 081-2 ... 50 082-2, EN 61 000-4-2 ...61 000-4-5
UL-Certification	USL according to UL508 (listed) / CNL according to C22.2 No: 142-M1987 (listed) Certified: E-File-No: E198563
Weight [kg]	2.0

Application example

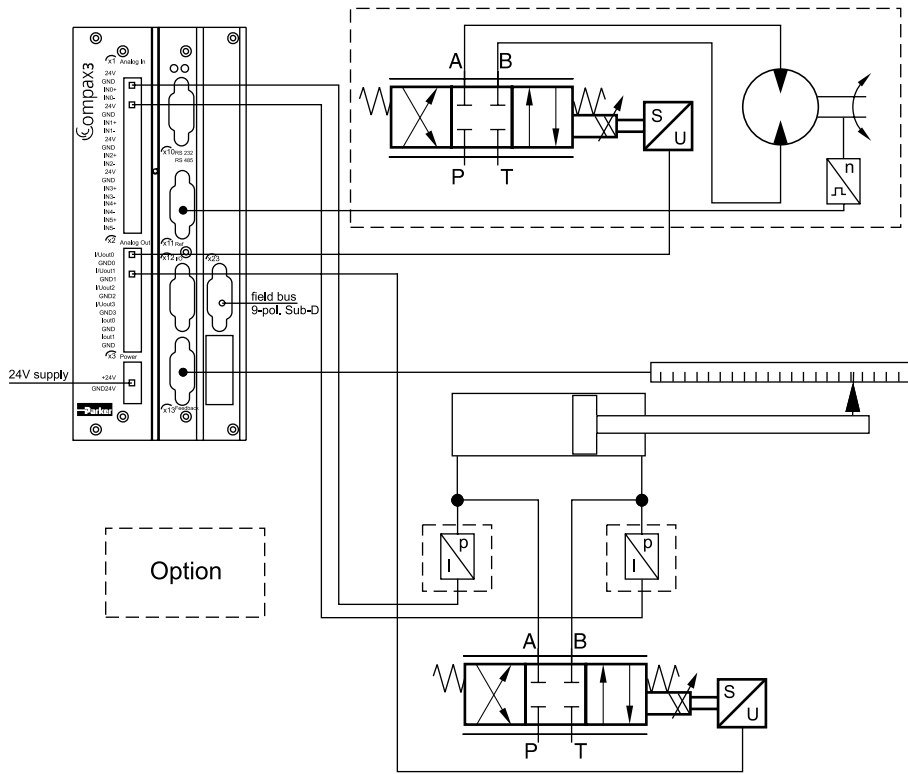

Dimensions

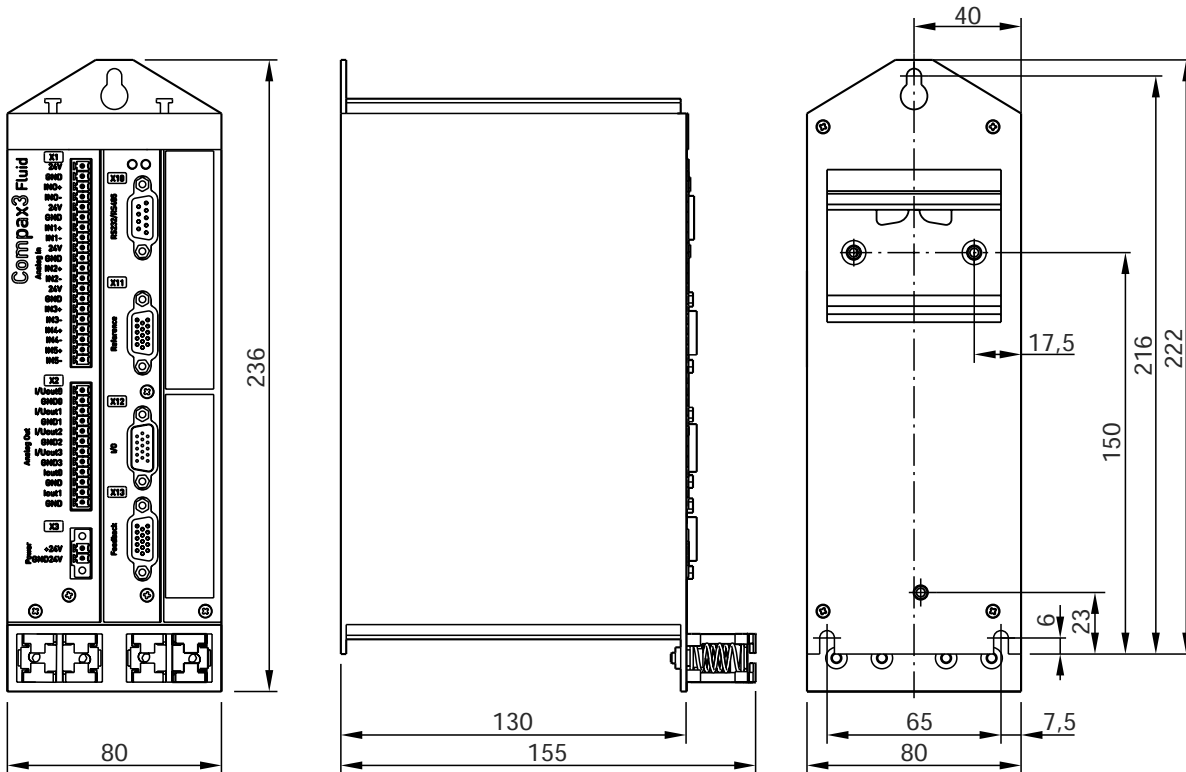

11

Project development, commissioning and programming



- **Compax3 ServoManager**
 - Intuitively understandable user interface
 - Wizard technology
 - Online help
 - Oscilloscope function
 - Optimized co-ordination of complete mechatronic systems
- **Valve and Drive manager**
 - All technical data of Parker valves, cylinders and drives available
 - Additionally support through the Compax3F Hydraulics-Manager by configuration of user defined valves and drives.

Software download, free of charge:
www.compax3.com

Operator Panels

Control equipment for all text and graphics applications in industrial environments, from two-line displays to touch-panels using field busses:

- Profibus DP
- CANopen
- DeviceNET
- Interbus-S

For further information please refer to POP: "Parker Operator Panels". Download: www.parker-eme.com/pop. In addition to drivers for Compax3/Compax3 powerPLmC, drivers for other PLC products can be integrated on request.



Service module

- Backlit plug-in module, text display with two sixteen-character lines
- Simple menu navigation with 4 keys
 - Display of status values and
 - clear text error messages
- Used for changing parameters and manual operation



ActiveX plug-in for Integration with the Office environment

- Office and industrial environments are constantly growing closer together.
- The use of ActiveX technology allows simple integration into Office application.

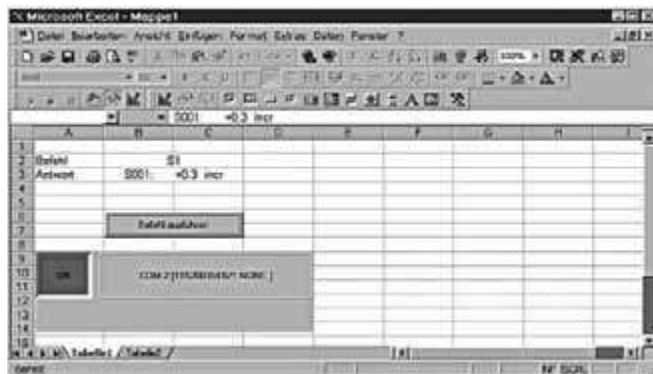

Interface - Field bus

- Profibus DP
- CANopen (CiADS402)
- DeviceNet
- PowerLink
- EtherCAT
- Profinet
- Address configurable via Dip switch

Connection of external inputs/outputs with Parker E/A-System (PIO)

Additional external digital and analog inputs and outputs can be integrated via the CANopen.



International standards in programming

- Programming system
 - CoDeSys
- Programming language
 - IEC61131-3
 - Function modules based on PLCopen



Jerk-limited set point generation, resulting in

- Gentle handling of the items being moved
- Increased service life of mechanical components
- Overshoot-free positioning
- Reduced excitation of mechanical resonance frequencies

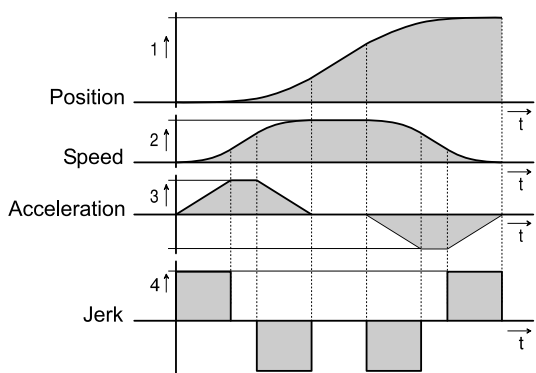

Control

a) General

- 2 control loops for each axis for combined position and force/pressure control

b) Position control

- Automatic controller design for position control
 - User-oriented optimization of parameters
- Feed forward control of speed and acceleration which results in:
 - Optimization of the response behaviour
 - Minimization of the following error

c) Force/Pressure controller

- PID controller with feed forward control of speed

d) 2-axis synchronous run and hydraulic specific functions

- Realization of many different circuit concepts with up to 4 proportional valves possible
- Linearization functions:
 - Consideration of the area of differential cylinders
 - Inverting of the valve set value
 - Compensation of the load pressure (additional pressure sensors necessary)
 - Correction of the nonlinear flow characteristic of the valve
 - Overlap compensation
 - Valve zero point correction
 - Valve set value filters
 - Valve set value limitation
 - All functions for each valve individually available
 - Automatic configuration by component selection in the Compax3 ServoManager

e) Custom-designed software packages on request

Set up controller optimization

- Compax3F HydraulicsManager
 - All necessary technical data of Parker valves and drives are available
 - additional supported
- Test movement for automatic controller attitude
- Optimization with integrated oscilloscope function
- Automatic pre-setting of the controller for position control possible

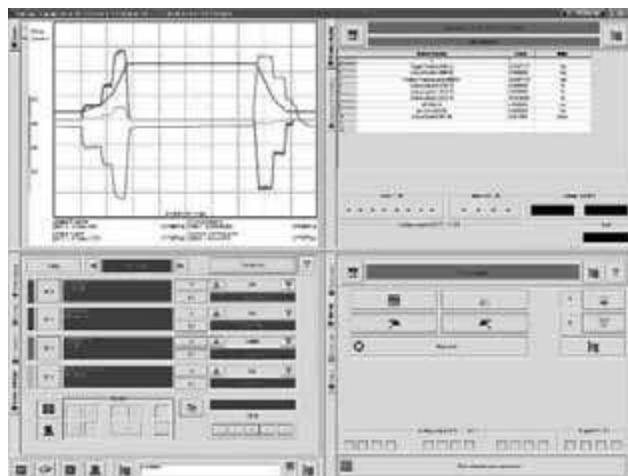

11

Overview technology functions

	T11	T30	T40
Set tables for up to 31 motion profiles	x		
Absolute or relative positioning	x	x	x
Force/pressure control	x	x	x
Electronic Gearbox	x	x	x
Dynamic positioning	x	x	x
Hydraulic specific control technology	x	x	x
Reg-related positioning	x	x	x
Programmable according to IEC61131-3		x	x
Programming system DoDeSys		x	x
Up to 6000 instructions		x	x
Recipe table with 288 variables		x	x
PLCopen		x	x
Mark synchronization			x
Cam switching mechanism			x
Cam profiles			x
Coupling and decoupling function			x
Custom-designed software packages*		O	O
Digital I/Os (RS232/485)	x	x	x
Profibus	O	O	O
CANopen		O	O
DeviceNet		O	O
Ethernet Powerlink		O	O
EtherCAT		O	O
Profinet	O	O	O

x = Standard
O = Optional
* on request

Benefits

- No programming skills necessary
- Set table with various motion
- Full controller range available
- An ideal basis for many applications in high-performance motion automation

Function range T11

- Set tables for positioning, pressure and force control up to 31 motion profiles:
 - Absolute or relative positioning
 - Force/pressure control
 - Speed control
 - Electronic gearing
- Superimposed force and pressure control
- Controller switching between position and force/pressure control

Extended Function range

- Absolute force control
- Superimposed force and pressure control
- Controller switching between position and force/pressure control
- 2-axis synchronous

Absolute or relative positioning

A motion set defines a complete motion with all settable parameters

1. Target position
2. Travel speed
3. Maximum acceleration
4. Maximum deceleration
5. Maximum jerk

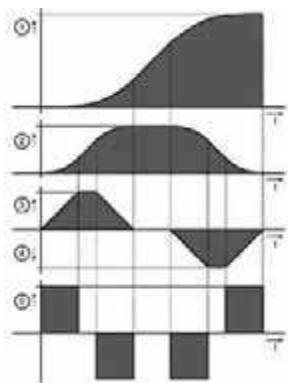

Stop movement

The Stop set interrupts the current motion set

Reg-related positioning

For registration mark-related positioning, 2 motions are defined:

- RegSearch: Search of an external signal, e.g. a registration mark on a product
- RegMove: The external signal interrupts the search movement and the second movement by an offset follows without transition
- Precision of the registration mark detection: <math><1\mu\text{s}</math>

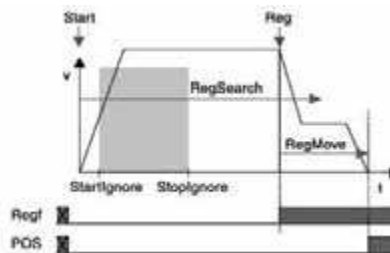

Electronic Gearbox:

Motion synchronized to a master axis with any transmission ratio. The position of a master axis can be detected via:

- $\pm 10\text{ V}$ analog input
- Step/direction command Input
- the encoder input or
- HEDA, with Compax3 Master

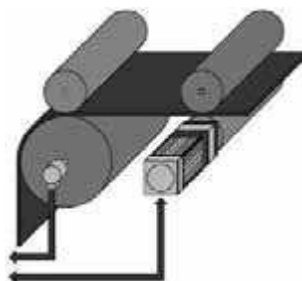

Dynamic positioning

A new motion profile can be selected during a positioning sequence - a smooth transition takes place.

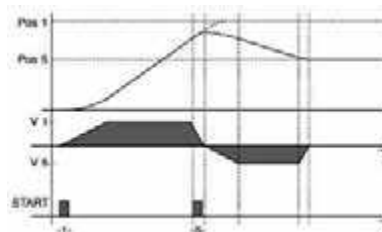

11

General

Due to its high flexibility and efficiency the Compax3 motion control according to PLCopen is for most applications the optimal basis for decentralized motion control.

Positioning with function modules based on PLCopen

- Programmable based on IEC61131-3
- Programming system: CoDeSys
- Up to 6000 instructions
- 500 16-bit variables / 150 32-bit variables
- Recipe table with 288 variables
- 3 16-bit saved variables (power failure protected) / 3 32-bit saved variables (power failure protected)
- PLCopen-function modules:
 - Positioning: absolute, relative, additive and continuous
 - Machine zero
 - Stop, energizing the power stage, quit
 - Position, device status, reading axis error
 - Electronic gearbox (Mc_GearIn)
- IEC61131-3-standard modules:
 - Up to 8 timers (TON, TOF, TP)
 - Trigger (R_TRIG, F_TRIG)
 - Flip-flops (RS, SR)
 - Counters (CTU, CTD, CTUD)
- Device-specific function modules:
 - C3_Input: reading digital inputs
 - C3_Output: writing digital inputs
 - C3_ReadArray: access to recipe table
- Inputs/outputs:
 - 8 digital inputs (24 V level)

- 4 digital outputs (24 V level)
- 6 analog inputs (14 bits)
- 4 analog outputs (16 bits)
- Optional addition of 12 digital inputs/outputs

PLCopen function blocks

- Absolute positioning
- Relative positioning
- Additive positioning
- Continuous positioning
- Stop
- Machine zero
- Energizing the power output stage
- Reading device status
- Reading axis error
- Acknowledging errors
- Reading the current position
- Electronic gearbox (gearing)

Example of an field bus interface controlled IEC61131-application

- 2 control words are placed on the cyclic channel of the bus.
- The position data records (position, speed, acceleration etc.) are stored in a table (array).
- The desired position data record is selected with Controlword_2.
- The individual bits of Controlword_1 control positioning.
- A return message is sent via a status word on the cyclic channel of the bus.

Example of a bus interface controlled IEC61131 application

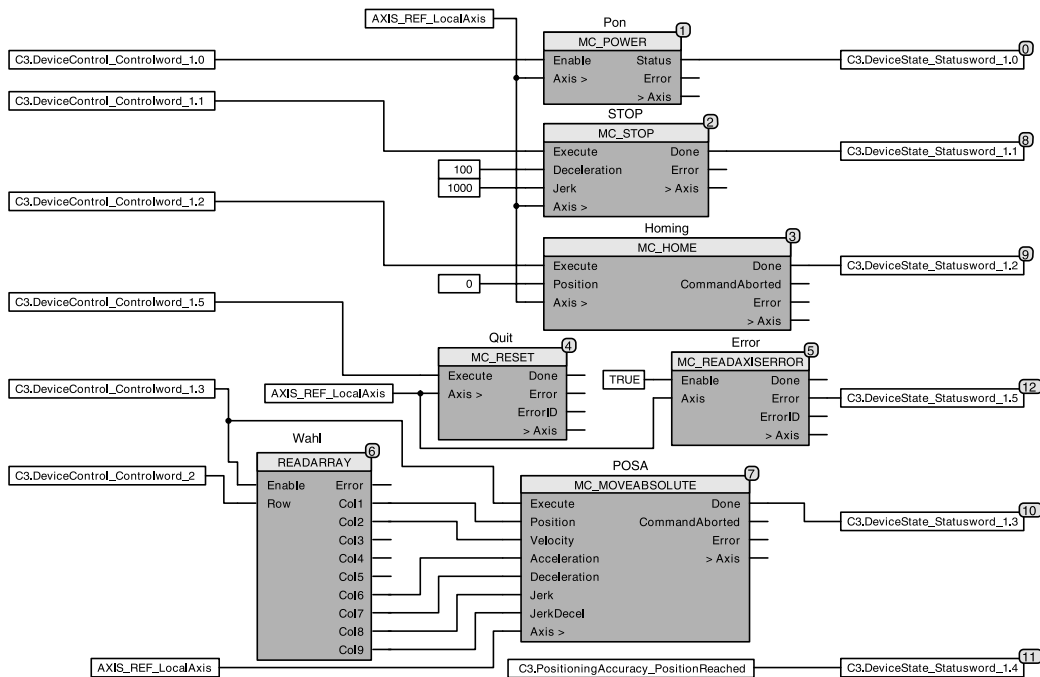

C3F UK.indd RH 29.08.2013

11

General

Compax3 T40 is able to simulate mechanical cams and cam switching mechanisms electronically. The T40 electronic cam was especially optimized for:

- The packaging machine industry
- The printing industry
- All applications, where a mechanical cam is to be replaced by a flexible, cyclic electronic solution

This helps to solve discontinuous material supply, flying-knife and similar drive applications using distributed drive technology.

Compax3 T40 supports both real and virtual master movements. In addition, the user can switch to other cam profiles or cam segments ,on the fly'.

Programming is carried out in the well-known IEC61131-3 environment.

With the aid of the cam function modules and CamDesigner, cam applications can be implemented very easily.

Function T40

- Technology functions of the T30 version fully integrated and available
- Master position acquisition
- Mark synchronization
- Cam switching mechanism
- Coupling and decoupling function
- Cam profiles
- Cam memory
- Cam creation with CamDesigner

Master position acquisition

- Acquisition by incremental encoder
- Acquisition by the HEDA real-time bus
- Virtual Master:

A second axis in the IEC program can be used to program a motion profile, which serves as a master for one or several axes.

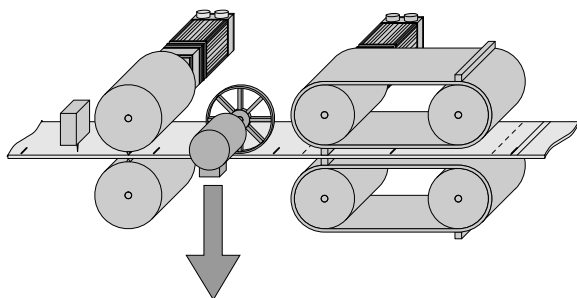

Mark synchronization

- Master or slave oriented (simultaneous, cam-independent)
- Highly-precise mark recognition (accuracy <math><1\mu\text{s}</math>; Touch-probe)

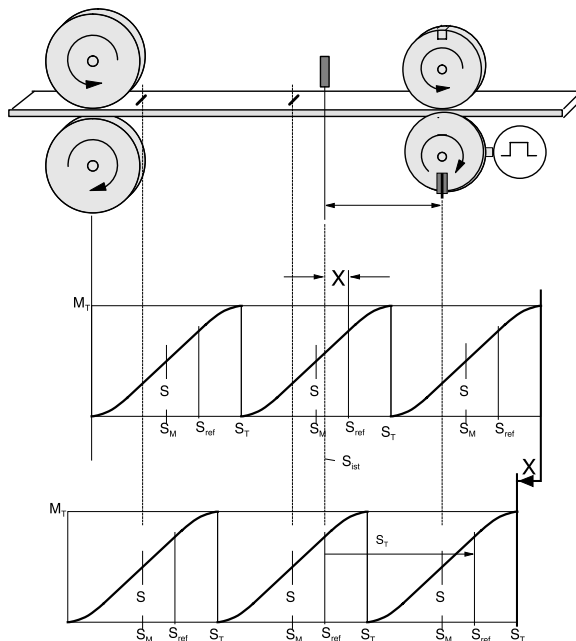

Cam switching mechanism

- 36 cams with individual profiles
- 4 fast cams (125 μs per cam) standard: 500 μs
- 32 serial cams, 16 ms/cam cycle (0.5 ms/cam)
- Delay-time compensated cams: Compax3 can advance the cam to compensate for delays in switching elements.

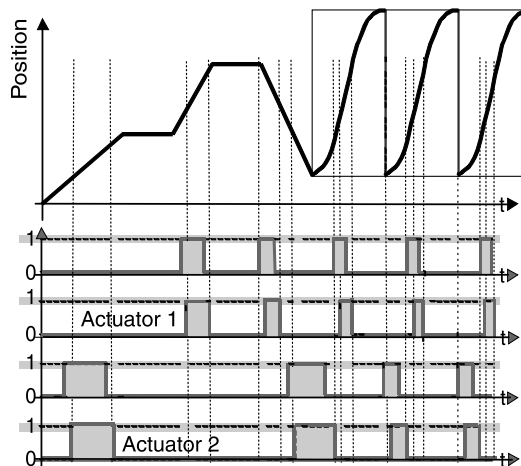

11

Coupling and decoupling functions

- By means of a set point generator
- By means of a change-over function
- Without overspeeding by coupling over several master cycles
- Virtually free set-up of the coupling and decoupling movement
- Master-guided coupling movement
- Random standstill position

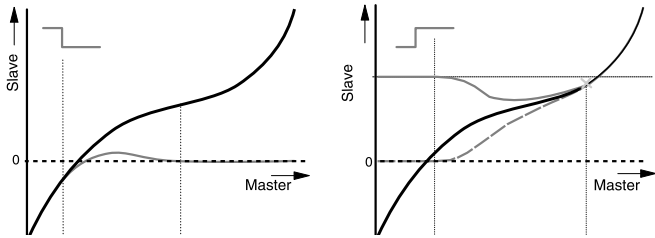

Cam profiles

- Up to 20 cam segments can be produced by:
- Virtually random cam links (forwards and backwards)
- Freely programmable event-controlled cam branches
- Scalable cam segments and complete cam profiles

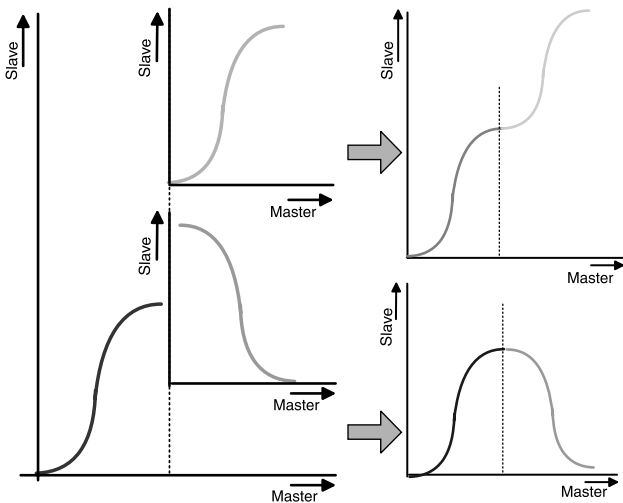

Cam memory

- 10,000 points (Master/Slave) in 24-bit format
- High-precision profile generation:
 - Variable point spacing with full backup of the current-master and slave coordinates (even if the power fails)
 - Linear interpolation between points
- Cam memory for up to 20 curves

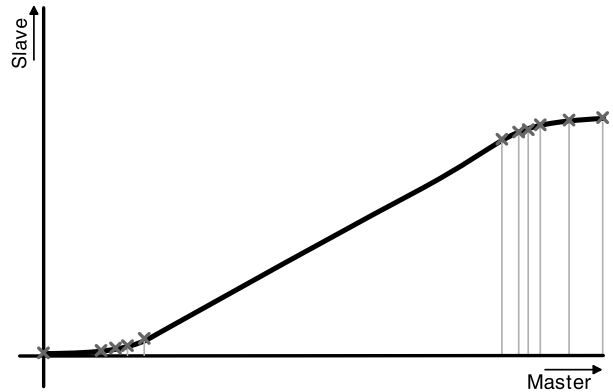

Connection of high-level controllers

**a) Control via digital inputs/outputs
Compax3 I11T30 / I11T40 / I12T11**

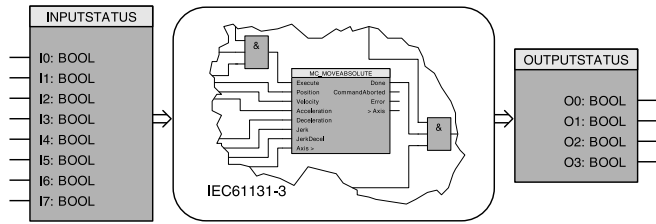

The digital I/Os can be optionally extended by 12 I/Os (M10 and M12 option).

**b) Control via Profibus,
Compax3 I20T11 / I20T30 / I20T40**

Profibus-ratings	
DP-Versions	DPV0 / DPV1
Baud rate [MBit/s]	up to 12
Profibus ID	C320

c) Control via CANopen, Compax3 I21T30 / I21T40

CANopen-ratings	
Baud rate [kBit/s]	20, 50, 100, 125, 250, 500, 800, 1000
Service-Data-Object	SDO1
Process-Data-Objects	PDO1, ... PDO4

d) Control via DeviceNet, Compax3 I22T30 / I22T40

DeviceNet-ratings	
I/O - data	up to 32 bytes
Baud rate [kBit/s]	125...500
Nodes	up to 63 Slaves

**e) Control via Ethernet Powerlink,
Compax3 I30T30 / I30T40**

Ethernet Powerlink ratings	
Baud rate	100 Mbits (FastEthernet)
Cycle time	<200 µs; to 240 nodes

**f) Control via EtherCAT
Compax3 I31T30 / I31T40**

EtherCAT-ratings	
Bau drate	100 Mbits (FastEthernet)
Cycle time	<200 µs; to 240 nodes

g) Control via Profinet I32T11 / I32T30 / I32T40

Profinet ratings	
Profinet version	Profinet IO (RT)
Transmission mode	100 BASE-TX (Full Duplex)
Profinet ID	C332

**h) Decentralized control via CANopen, I21T30 / I21T40
With external inputs/outputs (PIO)**

Additional external digital and analog inputs and outputs can be integrated via the CANopen master function. For this purpose we offer the Parker I/O system (PIO):

- CANopen field bus coupler: 650 mA/5 V, 1650 mA/5 V
- Digital input terminals: 2-, 4-, and 8-channel
- Analog input terminals: 2-channel (0-10 V), 4-channel (0-20 mA)
- Digital output terminals: 2-, 4-, and 8-channel
- Analog output terminals: 2-channel (0-10 V, 0-20 mA, +/-10 V)



11

Software Tool C3 ServoManager

Configuration is carried out on a PC using the Compax3 ServoManager.

- Wizard-guided configuration
 - Automatic querying of all necessary entries
 - Graphically supported selection
- Setup mode
 - Moving individual axes
 - Predefined profiles
 - Convenient operation
 - Storage of defined profiles
 - Controller pre-setting possible
- Integrated 4-channel oscilloscope
 - Signal tracing directly on the PC
 - Various modes (single/normal/auto/roll)
 - Zoom function
 - Export as image or table (for example to Excel)

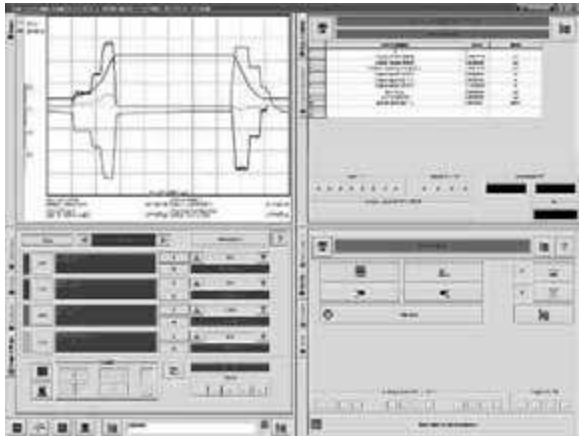

Software Tool HydraulicsManager

- Simple set up of customer valves, cylinders and drives.
- Technical data of all Parker valves, cylinders and drives available.



C3 HydraulicsManager valve database

Software Tool CamDesigner

- Standardized Nolte cam generating tool with:
 - Standard or extended range of functions
 - Evaluation of the motion profiles
 - Verification of the drive sizing
- Transition laws from VDI directive 2143:
 - Selection of motion laws
 - The CamDesigner basic version features 15 motion laws (based on the dwell-to-dwell (interpolation method))

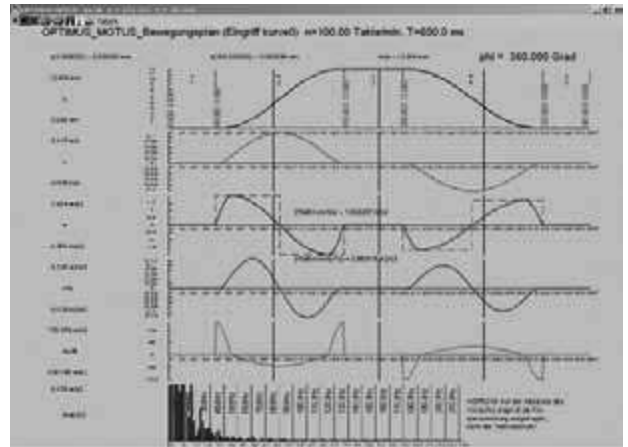

Evaluation of the motion profile

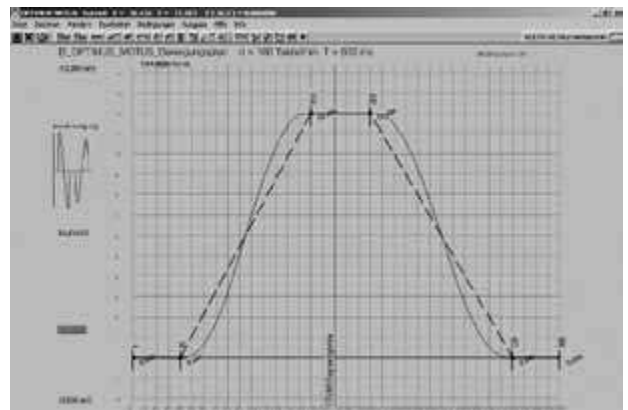

Cam generation with the integrated CamEditor

IEC61131-3 Programming language

IEC61131-3 is the only company- and product-independent programming language with worldwide support for industrial automation devices.

- IEC61131-3 includes graphical and textual programming languages:
 - Instruction list
 - Structured text
 - Ladder diagram
 - Sequential function chart
 - Function block diagram

Integrated standards offer:

- A trusted programming environment
- Standardized programming

Integrated standards reduce:

- The overhead of development
- Maintenance costs
- Software upkeep
- Training overhead

Integrated standards increase:

- Productivity
- Software quality
- Concentration on core competence

Examples

- Program development in IL

```

0001 FUNCTION_BLOCK AWL_EXAMPLE
0002 (* Sinus und CoSinus einer Zahl berechnen *)
0003 VAR_INPUT
0004   r1: REAL := 0.0;
0005 END_VAR
0006 VAR_OUTPUT
0007   sinus: REAL;
0008   cosinus: REAL := 9.9;
0009 END_VAR
0010
0011 (* Den Sinus einer Zahl berechnen und mit 1000 multiplizieren *)
0012 LD   r1
0013 SIN
0014 MUL  1000.0
0015 ST   sinus
0016
0017 (* Den Cosinus einer Zahl berechnen und mit 1000 multiplizieren *)
0018 LD   r1
0019 COS
0020 MUL  1000.0
0021 ST   cosinus
0022
0023 (* Die Zahl wegschalten *)
0024 LD   r1
0025 ADD  0.1
0026 ST   r1
    
```

- Instruction list (IL)

```

LD      A
ANDN   B
ST     C
    
```

- Ladder diagram

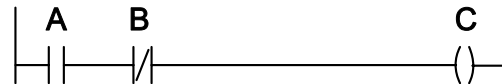

- Structured text

C := A AND NOT B

- Function plan

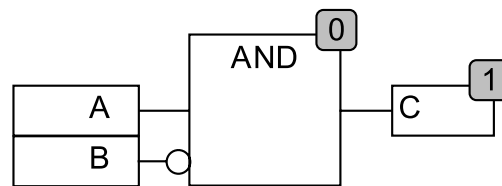

Function modules based on PLCopen

PLCopen is a product- and company independent organization that plays a significant role in supporting the IEC61131-3 programming language. Its specific tasks also include defining basic processes relevant to motion. The PLCopen organization consists of both users and manufacturers of automation components.

Parker Hannifin is an active member of the "Motion Control" task force. This is a great advantage for the users of Parker drive technology, since they are constantly able to profit directly from the latest developments in PLCopen.



Professional development tool CoDeSys

CoDeSys is a development environment for programming that saves a significant amount of time as applications are created.

- One of the most powerful development environments available, established world-wide
- Universal programming platform for various devices
- Visual elements
- Library management for user-defined applications
- Context-sensitive help wizard
- Data exchange between devices from different manufacturers
- Complete online functionality
- Sophisticated technological features
- Standard function modules deposited
- ... and all this for no additional cost

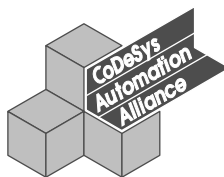

Parker is a member of the "CoDeSys Automation Alliance".

Program development in CFC

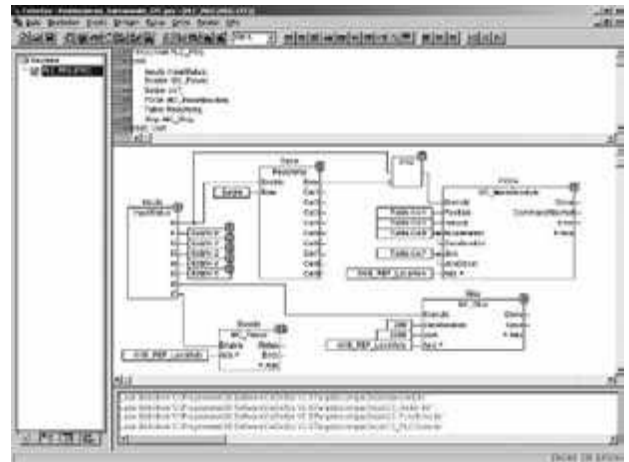

Project management

Saving an entire project (source file) including symbols and comments to make service calls easier, because there is no need for any project data on the device itself

- Archiving projects as ZIP files
- Creating user-specific libraries that can be reused as tested sections of programs
 - These libraries can be protected
 - Examples include winders, synchronization components etc.
- Various user levels make it possible to lock sections of the program with passwords
- Depending on the task at hand, users can select from among 5 IEC languages plus CFC. These languages can also be mixed

Connection set ZBH../.. (included in delivery)

Complete kit with mating plug connectors (X1, X2 and X3) for Compax3 connectors, special shield connecting terminal and snap-on foot for mounting rail.



Feedback cable GBK../..

Connection to the Motor:

Under the designation "REK.. + GBK.." (Feedback cable) we can deliver feedback connecting cables in various lengths to order.

- Prefabricated with plug and cable eye
- The plugs of the Parker motor and feedback cables contain a special surface area screening.
- Cable plans, if you wish to make up your own cables



Terminal block EAM06/..

For additional wiring of the inputs and outputs:

- Available with or without LED display
- Can be mounted in the control cabinet on a supporting rail
- Connection EAM06/.. via SSK23/..to X11, SSK24/..to X12

RS232 cable SSK01/..

(in various lengths).

Configuration:

Via a PC with the aid of the Compax3 ServoManager.

Communication:

Communication with Compax3 either via RS232 or via RS485 in order to read or write into objects.



Profibus plug BUS08/01

- BUS08/01 with 2 cable inputs (1x BUS08/01 incoming, 1x BUS08/01 continuing) and screw terminals, as well as a switch for activating the terminating resistor. Set to ON for first and last bus node terminating resistor activated.

Profibus cable: SSL01/.. not prefabricated

- Special cable in any length for Profibus wiring (colors according to DESINA).



Operating module BDM01/01

For display and diagnosis purposes:

- Can be plugged in during operation
- Power supply via Compax3 servo control
- For displaying and changing values



HEDA Bus

HEDA bus terminal connector (RJ45) BUS07/01:

- For the first and last Compax3 in the HEDA bus.

HEDA cable: SSK28/.. prefabricated in various lengths:

- Cable for HEDA bus wiring from Compax3-to-Compax3 or PC-to-Compax3 powerPLmC or wiring of
 - Ethernet Powerlink (I30)
 - EtherCAT (I51)
 - Profinet (I32)



11

CANbus plug BUS10/01

- BUS10/01 with 2 cable inputs (1x BUS10/01 incoming, 1x BUS10/01 continuing) and screw terminals, as well as a switch for activating the terminating resistor. Set to ON for first and last bus node terminating resistor activated

CANbus cable SSL02/.. not prefabricated

- Special cable in any length for CANbus wiring (colours according to DESINA)



External Inputs/Outputs PIO...

For Compax3 I21 from technology function T30 onwards via CANopen:

- Integration of additional external input and output modules (digital and analog)



Connection set for Compax 3										
for C3F001 D2 F12xxx	ZBH 02/04	Z	B	H	0	2	/		0	4
Operating module										
Operating module		B	D	M	0	1	/		0	1
Terminal block										
for I/Os without luminous indicator	for X11, X12	E	A	M	0	6	/		0	1
for I/Os with luminous indicator	for X12	E	A	M	0	6	/		0	2
Interface cables and connectors										
PC-Compax3 (RS232)		S	S	K	0	1	/	 ¹⁾
on X11/X13 (Transducer)	With flying leads	S	S	K	2	1	/	 ¹⁾
on X12 (I/O digital)	With flying leads	S	S	K	2	2	/	 ¹⁾
on X11(Ref/Analog)	For I/O terminal	S	S	K	2	3	/	 ¹⁾
on X12 (I/Os digital)	For I/O terminal	S	S	K	2	4	/	 ¹⁾
PC - POP (RS232)		S	S	K	2	5	/	 ¹⁾
Compax3 - POP (RS485)		S	S	K	2	7	/ ³⁾
Compax3 HEDA - Compax3 HEDA										
or PC - C3powerPLmC										
or Ethernet Powerlink (I30), EtherCAT (I31), Profinet (I32)		S	S	K	2	8	/	 ²⁾
Compax3 X11 - Compax3 X11 (Encoder coupling of 2 axes)		S	S	K	2	9	/	 ¹⁾
HEDA bus terminal connector (for the 1st and the last Compax3 in the HEDA Bus)		B	U	S	0	7	/		0	1
Feedback cable for Balluff SSI transducer and start/stop		G	B	K	4	0	/	 ¹⁾
Feedback cable for SSI transducer and start/stop	With flying leads	G	B	K	5	3	/	 ¹⁾
Profibus cable ⁴⁾	Not prefabricated	S	S	L	0	1	/	 ¹⁾
Profibus connector		B	U	S	0	8	/		0	1
CAN-Bus cable ⁴⁾	Not prefabricated	S	S	L	0	2	/	 ¹⁾
CAN-Bus connector		B	U	S	1	0	/		0	1

Length code for SSK27

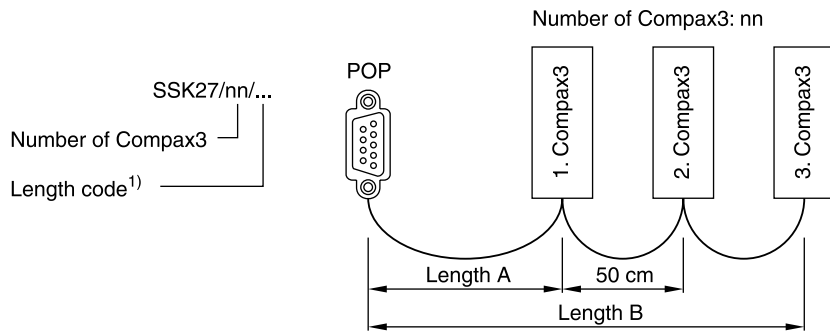

¹⁾ Length code

Length code 1 (Example: SSK01/09: Length 25 m)

Length [m]	1.0	2.5	5.0	7.5	10.0	12.5	15	20	25	30	50
Code	01	02	03	04	05	06	07	08	09	10	14

²⁾ Length code for SSK28

Length code 2 (Example: SSK28/22: Length 3 m)

Length [m]	0.25	0.5	1.0	3.0	5.0	10.0
Code	20	21	01	22	03	05

³⁾ Length code for SSK27

Length A: Cable or connection from POP with **one** Compax3 (POP - 1.Compax3), variable length according to length code¹⁾
 (Example: SSK27/01/01: Length 1.0 m)

Length B: Cable or connection from POP with **more than one** Compax3 (nn > 01) (1.Compax3 - 2.Compax3 - ...), length between Compax connectors is fixed to 50 cm, variable length A from POP with first Compax according to length code¹⁾
 (Example: SSK27/03/01: Length 1.0 m)

⁴⁾ Colours according to DESINA

Decentralized Input terminals						
PIO 2DI 24 VDC 3.0 ms	2-Channel Digital-Input terminal		P	I	O	4 0 0
PIO 4DI 24 VDC 3.0 ms	4-Channel Digital-Input terminal		P	I	O	4 0 2
PIO 8DI 24 VDC 3.0 ms	8-Channel Digital-Input terminal		P	I	O	4 3 0
PIO 2AI DC ±10 V	2-Channel Analog-Input terminal	(± 10 V Differential input)	P	I	O	4 5 6
PIO 4AI 0-10 V DC S.E.	4-Channel Analog-Input terminal	(0-10 V Signal voltage)	P	I	O	4 6 8
PIO 2AI 0-20 mA	2-Channel Analog-Input terminal	(0 - 20 mA Differential input)	P	I	O	4 8 0
Decentralized Output terminals						
PIO 2DO 24 VDC 0.5 A	2-Channel Digital-Output terminal	(Output current 0.5 A)	P	I	O	5 0 1
PIO 4DO 24 VDC 0.5 A	4-Channel Digital-Output terminal	(Output current 0.5 A)	P	I	O	5 0 4
PIO 8DO 24 VDC 0.5 A	8-Channel Digital-Output terminal	(Output current 0.5 A)	P	I	O	5 3 0
PIO 2AO 0-10 VDC	2-Channel Analog-Output terminal	(0-10 V Signal voltage)	P	I	O	5 5 0
PIO 4AO 0-20 mA	2-Channel Analog-Output terminal	(0-20 mA Signal voltage)	P	I	O	5 5 2
PIO 2AO DC ±10 V	2-Channel Analog-Output terminal	(±10 V Signal voltage)	P	I	O	5 5 6
CANopen Fieldbus coupler						
CANopen Standard			P	I	O	3 3 7
CANopen ECO			P	I	O	3 4 7

Characteristics

The new test unit EX00-M05 is suitable for testing and commissioning of all proportional and servo proportional valves with onboard electronics that are offered in this catalogue.

For easy on-site service all necessary cables are securely located inside of the rugged case. The test unit provides all command signal sources and measuring ports for concerted and time saving control and diagnosis of the valves. For operation of the new hybrid regenerative valves an additional switchable 24 V output is available.

Features

- Control of valves incorporating integrated electronics and central plug acc. DIN 43563 (6-pin + PE)
- Built-in fuses
- Cable set included
- Lockable rugged box



Ordering code

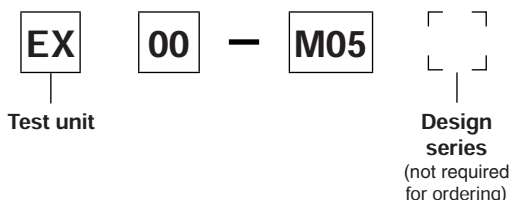

Technical data

Design	Lockable rugged box, polypropylene (break proof)		
Supply voltage	[V]	85...260, 50...60 Hz	
Power consumption	[VA]	max. 160	
Current consumption max.	[A]	1.3 at 230 V	
Main input fuse	[A]	3.15 time lag	
Required main supply fuse	[A]	16	
Protection class	IP40		
EMC	EN 61000-6-2		
Valve central connection	Valve supply	[V] 24 (±5 %)	
	Command voltage	[V] 0...±10 (±1 %), 0...10, 0...±20 mA, 0...20 mA, 4...12...20 mA, 4...20 mA	
	Diagnostic output	0...±10 V / 0...±20 mA	
	Enable signal	[V] 7.5 (±10 %)	
Measurement terminals	For multimeter with Ri min = 10 kOhm		
Display	Display digits	4	
	Resolution	10 mV / 10 mA ; 1 digit	
Main cord	Unit site	Cable inlet connector IEC320	
	Main site	CEE 7/7 plug	
	Cable length [m]	2	
Valve cords	Unit site	A - control valves	B - DC valves
		Connector Amphenol SV70 DIN 40040	Connector 6+PE acc. EN175201-834
	Valve site	Connector DIN 43563	M12x1 as per IEC61076-2-101
		Cable length [m]	3
Ambient temperature	[°C]	0...40	
Weight	[kg]	3.9	
Dimensions	[mm]	L 305 x B 270 x H 144	

EXM05 UK.indd RH 29.08.2013

11

Operator panel
Front

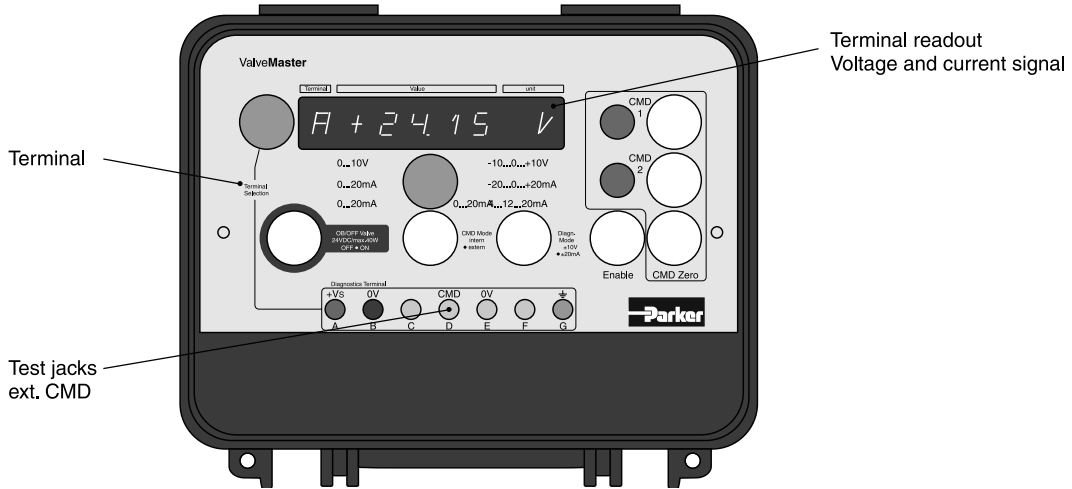

Rear

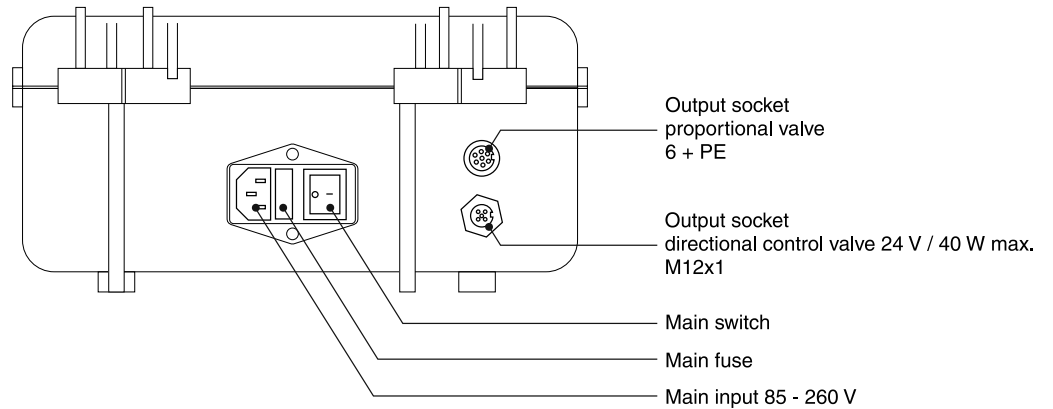

Wiring configuration

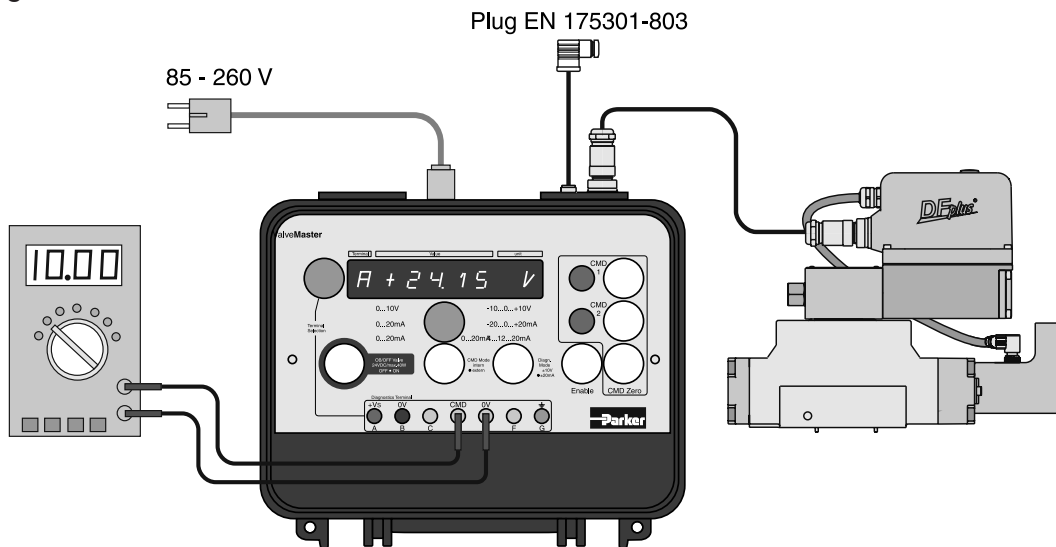

11